

EPA Example Construction SWPPP:

Medium-Sized (~20-acre) Residential Subdivision

Introduction

This example Stormwater Pollution Prevention Plan (SWPPP) was prepared using the U.S. Environmental Protection Agency's (EPA's) guide, *Developing Your Stormwater Pollution Prevention Plan: A Guide for Construction Operators* and its accompanying SWPPP template. Both the SWPPP Guide and the SWPPP template are available at <http://www.epa.gov/npdes/swpppguide>. The instructions and references in this SWPPP refer to the SWPPP template and are left in for illustrative purposes. The SWPPP guide, SWPPP template, and this hypothetical SWPPP example are provided for compliance assistance purposes only; for a complete list of permit requirements, refer to EPA's Construction General Permit at: <http://www.epa.gov/npdes/stormwater/cgp>.

Use of this example SWPPP

This example SWPPP represents a hypothetical project for the construction of a residential subdivision on 20 acres in Idaho. For this example, the SWPPP was prepared in November 2005 with construction commencing in May 2006. To illustrate how an actual SWPPP should be used, this example SWPPP includes marked-up edits to pages and copies of records such as inspection reports. For purposes of this example, this SWPPP was copied on August 15, 2006. Therefore, inspection reports and other records are current as of that date.

This example SWPPP was developed for EPA's 2003 Construction General Permit (CGP), as modified effective January 21, 2005. If you are subject to a different general permit issued by a state or EPA Region, your requirements and SWPPP template might be slightly different.

Disclaimer

This SWPPP is for a hypothetical project. Any similarities to actual construction projects, operators, or places are purely coincidental.

Do not copy this SWPPP for your project! The best management practices and explanatory text in this SWPPP are intended to apply only to this hypothetical site. Each SWPPP must be created on a case-by-case basis to address the unique conditions and issues at a given construction site. Relying on the wording in this hypothetical SWPPP is discouraged and will not necessarily result in compliance with the Construction General Permit.

Stormwater Pollution Prevention Plan

for:

Clover Hills Subdivision
2202 Williams Avenue
Stormville, ID 83341
(208) 444-4444

Operator(s):

RBI Development, LLC
Mr. Doug Lewis
13 South Avenue
Boise, ID 83701
(208) 555-5555
Dlewis@rbi.com

SWPPP Contact(s):

Ms. Dorothy Williams
RBI Development, LLC
13 South Avenue
Boise, ID 83701
(208) 555-5555
Dwilliams@rbi.com

SWPPP Preparation Date:

11/01/2005

Estimated Project Dates:

Project Start Date: 05/05/2006
Project Completion Date: 10/01/2008

AMENDMENT # 3 6/6/06 JS

Operator:

Coastal Creek Building, Inc.
Mr. Darren Shaw, Owner
445 Hunter Road
Bend, OR 97701
(503) 222-2222
darren.shaw@coastbuild.com

Contents

SECTION 1: SITE EVALUATION, ASSESSMENT, AND PLANNING	1
1.1 Project/Site Information	1
1.2 Contact Information/Responsible Parties	2
1.3 Nature and Sequence of Construction Activity	5
1.4 Soils, Slopes, Vegetation, and Current Drainage Patterns	7
1.5 Construction Site Estimates	8
1.6 Receiving Waters	8
1.7 Site Features and Sensitive Areas to be Protected	10
1.8 Potential Sources of Pollution.....	10
1.9 Endangered Species Certification	12
1.10 Historic Preservation	13
1.11 Applicable Federal, Tribal, State or Local Programs	14
1.12 Maps	14
SECTION 2: EROSION AND SEDIMENT CONTROL BMPs.....	15
2.1 Minimize Disturbed Area and Protect Natural Features and Soil.....	16
2.2 Phase Construction Activity.....	17
2.3 Control Stormwater Flowing onto and through the Project	18
2.4 Stabilize Soils	21
2.5 Protect Slopes	23
2.6 Protect Storm Drain Inlets	25
2.7 Establish Perimeter Controls and Sediment Barriers	28
2.8 Retain Sediment On-Site.....	32
2.9 Establish Stabilized Construction Exits	34
2.10 Additional BMPs	37
SECTION 3: GOOD HOUSEKEEPING BMPs	38
3.1 Material Handling and Waste Management.....	38
3.2 Establish Proper Building Material Staging Areas	40
3.3 Designate Washout Areas.....	41
3.4 Establish Proper Equipment/Vehicle Fueling and Maintenance Practices.....	43
3.5 Control Equipment/Vehicle Washing	44
3.6 Spill Prevention and Control	44
3.7 Any Additional BMPs.....	45
3.8 Allowable Non-Stormwater Discharge Management	46
SECTION 4: SELECTING POST-CONSTRUCTION BMPs	48
SECTION 5: INSPECTIONS	50
5.1 Inspections	50
5.2 Delegation of Authority	52
5.3 Corrective Action Log	52
SECTION 6: RECORDKEEPING AND TRAINING	53
6.1 Recordkeeping	53
6.2 Log of Changes to the SWPPP	53
6.3 Training	54
SECTION 7: FINAL STABILIZATION.....	55

SECTION 8: CERTIFICATION AND NOTIFICATION..... 57
SWPPP APPENDICES 58
Appendix A – General Location Map
Appendix B – Site Maps
Appendix C – Construction General Permit
Appendix D – NOI and Acknowledgement Letter from EPA/State
Appendix E – Inspection Reports
Appendix F – Corrective Action Log (or in Part 5.3)
Appendix G – SWPPP Amendment Log (or in Part 6.2)
Appendix H – Subcontractor Certifications/Agreements
Appendix I – Grading and Stabilization Activities Log (or in Part 6.1)
Appendix J – Training Log
Appendix K – Delegation of Authority
Appendix L – Additional Information (i.e, Endangered Species and Historic Preservation Documentation)

Tables

Table 1. Timeline of Activity 5
Table 2. Potential construction site pollutants 11

Figures

Figure 1. Earth dike 19
Figure 2. Vegetated swale 20
Figure 3. Erosion control blanket 24
Figure 4. Silt fence storm drain inlet protection..... 26
Figure 5. Gravel bag barriers..... 27
Figure 6. Silt fence 29
Figure 7. Fiber rolls 31
Figure 8. Sediment basin 33
Figure 9. Stabilized construction exit..... 35
Figure 10. Stabilized construction exit (individual lot)..... 36
Figure 11. Temporary concrete washout 43

SECTION 1: SITE EVALUATION, ASSESSMENT, AND PLANNING

1.1 Project/Site Information

Instructions:

- In this section, you can gather some basic site information that will be helpful to you later when you file for permit coverage.
- For more information, see *Developing Your Stormwater Pollution Prevention Plan: A SWPPP Guide for Construction Sites* (also known as the *SWPPP Guide*), Chapter 2
- Detailed information on determining your site's latitude and longitude can be found at www.epa.gov/npdes/stormwater/latlong

Project/Site Name: Clover Hills Subdivision

Project Street/Location: 2202 Williams Avenue

City: Stormville State: ID ZIP Code: 83341

County or Similar Subdivision: Twin Falls County

Latitude/Longitude (Use **one** of three possible formats, and specify method)

Latitude:

Longitude:

1. 42 ° 33 ' 48 " N (degrees, minutes, seconds) 1. 114 ° 25 ' 30 " W (degrees, minutes, seconds)

2. ___ ° ___ . ___ ' N (degrees, minutes, decimal) 2. ___ ° ___ . ___ ' W (degrees, minutes, decimal)

3. ___ . ___ ° N (decimal) 3. ___ . ___ ° W (decimal)

Method for determining latitude/longitude:

USGS topographic map (specify scale: 1:24,000) EPA Web site GPS

Other (please specify): _____

Is the project located in Indian country? Yes No

If yes, name of Reservation, or if not part of a Reservation, indicate "not applicable." _____

Not Applicable

Is this project considered a federal facility? Yes No

NPDES project or permit tracking number*: RBI : IDR 10 BNO

*(This is the unique identifying number assigned to your project by your permitting authority after you have applied for coverage under the appropriate National Pollutant Discharge Elimination System (NPDES) construction general permit.)

AMENDMENT # 7 7/5/20 DW

COASTAL CREEK BUILDING PERMIT TRACKING NUMBER: IDR 10 BNO

1.2 Contact Information/Responsible Parties

Instructions:

- List the operator(s), project managers, stormwater contact(s), and person or organization that prepared the SWPPP. Indicate respective responsibilities, where appropriate.
- Also, list subcontractors expected to work on-site. Notify subcontractors of stormwater requirements applicable to their work.
- See *SWPPP Guide*, Chapter 2.B and EPA's Construction General Permit (CGP) Part 3, Subparts 3.2, 3.3.A, and 3.4.A.

Operator(s):

See Appendix B – Ownership Site Map for geographic area of control.

OPERATOR	
Contact Information	Geographic Area of Control*
RBI Development, LLC Mr. Doug Lewis, Owner 13 South Avenue Boise, ID 83701 Office Phone: (208) 555-5555 Email: Dlewis@rbi.com	RBI Development owns the 20-acre parcel of land and is developing the Clover Hills Subdivision. RBI Development is the initial permittee applying for permit coverage and will be primarily responsible for developing and implementing this SWPPP. RBI Development is responsible for overall site development of lots A1–C10 including grading and infrastructure of these lots but only constructing houses on lots A2–A16. RBI Development will implement and maintain the best management practices (BMPs) specified in Sections 2 and 3, conduct inspections (Section 5) and address stormwater over the entire site including all areas disturbed by construction activities, areas used for materials storage, discharge points, and construction exits. RBI Development has entered into contract to sell lots B1–B9 to Falls Homes and lots C1–C10 to Coastal Creek Building for individual housing construction. RBI Development will also assume responsibility of inspecting lots C1–C10 for Coastal Creek Building. Lots B1–B9 will be covered under a separate SWPPP developed by Fall Homes and will not be covered by this SWPPP after these lots are sold to Fall Homes.
<p>* See Construction Operator's Cooperative Agreement</p>	

See Appendix B – Ownership Site Map for geographic area of control.

OPERATOR	
Contact Information	Geographic Area of Control*
Coastal Creek Building, Inc. Mr. Darren Shaw, Owner 445 Hunter Road Bend, OR 97701 (503) 222-2222 darren.shaw@coastbuild.com	Coastal Creek Building has entered into a contract with RBI Development to purchase lots C1–C10 and commence building on lots C1–C5. Coastal Creek Building will apply for permit coverage concurrent with RBI Development. Coastal Creek Building has agreed to implement this SWPPP in cooperation with RBI Development. Coastal Creek Building will implement and maintain BMPs for individual lots specified in Sections 2 and 3 of this SWPPP and RBI Development will conduct inspections on lots C1–C10 in compliance with this SWPPP. Inspection reports and records will be provided to Coastal Creek Building by RBI Development.
<p>* See Construction Operator’s Cooperative Agreement</p>	

Project Manager(s):

Mr. Tony Groff, Project Manager
 Coastal Creek Building, Inc.
 445 Hunter Road
 Bend, OR 97701
 (503) 222-2222
 tony.groff@coastbuild.com

Construction Operators' Cooperative Agreement

This cooperative agreement describes stormwater responsibilities for all construction operators working on the Clover Hills subdivision project. The operators below agree to abide by the following conditions throughout the duration of the construction project, effective the date of signature. These conditions apply to all operators on the site, regardless of whether an operator develops its own Storm Water Pollution Prevention Plan (SWPPP) or agrees to be covered under the one created by RBI Development.

This project is subject to EPA's NPDES General Permit for Storm Water Discharges from Construction Activities (Construction General Permit or CGP). The goal of this permit is to prevent the discharge of pollutants associated with construction activity from entering the storm drain system or surface waters. RBI Development, Inc. (RBI) has developed a SWPPP for the Clover Hills Subdivision project, and it is available for review at the on-site construction trailer.

RBI Development, Inc.'s Responsibilities:

- RBI will maintain the SWPPP documentation and will conduct and document self-inspections required under Part 3.10 of the CGP on a weekly basis and within 24 hours of the end of a storm event of one-half inch or greater in all areas of the site covered by this SWPPP.
- RBI will provide copies of inspection reports to the other operators covered by this SWPPP within 24 hours following each inspection.
- RBI will be responsible for maintaining the cleanliness of the streets (Johnson Loop and Williams Avenue) and storm drain inlet protection Best Management Practices (BMPs) throughout the construction project. RBI will conduct street sweeping on a weekly basis and prior to forecasted rain events. RBI will also inspect and replace storm drain inlet protection BMPs as necessary.
- RBI will hold biweekly meetings to update operators on CGP compliance issues.
- RBI will maintain erosion and sediment control BMPs in all areas of the site under its day-to-day control.
- RBI will provide adequate designated concrete washout areas to all operators throughout the construction project and will be responsible for proper disposal of the concrete, mortar or grout collected there.

Homebuilders' Responsibilities:

- Costs incurred by RBI to address excess sediment discharges, debris or spills on roadways that result from an operator or subcontractor's negligence will be reimbursed by the responsible operator.
- If the operator or its subcontractor damages a storm drain inlet BMP, the operator will pay RBI \$200.00 for each inlet BMP that must be replaced.
- Operator shall not store erodible or hazardous materials on any roadway.
- Operator shall be responsible for maintaining compliance with the applicable SWPPP, including installation of erosion and sediment controls, within the individual lots under its day-to-day control. Any BMP changes that would trigger the need for a SWPPP modification shall be promptly communicated to RBI.
- Operator shall use the designated concrete washout area(s) provided by RBI to dispose of any excess concrete, mortar and grout.

Construction Operators' Cooperative Agreement

Joint Responsibilities:

- Each operator shall file a Notice of Intent (NOI) to be covered by the Construction General Permit before beginning construction at the project, and permit coverage will be maintained throughout the project.
- No operator shall file a Notice of Termination (NOT) until all disturbed areas of the site under its day-to-day control have been effectively stabilized with permanent erosion controls that satisfy the final stabilization requirement in the CGP; the only allowed exception is those areas that have been effectively stabilized with temporary erosion controls and turned over to a private landowner.
- Operators will maintain a clean site. Trash and debris will be picked up and disposed of properly by the end of each day.
- Each operator is responsible for advising employees and subcontractors working on this project of the requirements in the CGP and applicable SWPPP. Particular emphasis should be placed on ensuring that employees and subcontractors do not damage BMPs and do not introduce pollutants into the storm drain system.

The undersigned agree to abide by the terms and conditions of this cooperative agreement as described above.

RBI Development, Inc.
Operator

Doug Lewis
Signature

OWNER
Title

6/2/06
Date

In addition, I agree to comply with and be covered by RBI's SWPPP for this project.

I agree to the terms above, but choose to develop my own SWPPP rather than sign onto RBI's SWPPP for this project.

COASTAL CREEK BUILDING
Operator Name

Damen Shaw
Signature

OWNER
Title

6/2/06
Date

AMENDMENT # 13 9/7/2006 JS

See Appendix B – Ownership Site Map for geographic area of control.

OPERATOR (Not covered under this SWPPP)	
Contact Information	Geographic Area of Control*
Falls Homes, LLC Mr. Drew Falls, Owner 2123 Commercial Way Twin Falls, ID 83301 (208) 333-3333	Falls Homes has entered into a contract with RBI Development to purchase lots B1–B9 and commence building on all purchased lots. (Falls Homes will develop its own SWPPP for lots B1–B9 and will obtain NPDES Stormwater Permit Coverage separately from RBI Development.)
* See Construction Operator’s Cooperative Agreement	

Construction Operators' Cooperative Agreement

This cooperative agreement describes stormwater responsibilities for all construction operators working on the Clover Hills subdivision project. The operators below agree to abide by the following conditions throughout the duration of the construction project, effective the date of signature. These conditions apply to all operators on the site, regardless of whether an operator develops its own Storm Water Pollution Prevention Plan (SWPPP) or agrees to be covered under the one created by RBI Development.

This project is subject to EPA's NPDES General Permit for Storm Water Discharges from Construction Activities (Construction General Permit or CGP). The goal of this permit is to prevent the discharge of pollutants associated with construction activity from entering the storm drain system or surface waters. RBI Development, Inc. (RBI) has developed a SWPPP for the Clover Hills Subdivision project, and it is available for review at the on-site construction trailer.

RBI Development, Inc.'s Responsibilities:

- RBI will maintain the SWPPP documentation and will conduct and document self-inspections required under Part 3.10 of the CGP on a weekly basis and within 24 hours of the end of a storm event of one-half inch or greater in all areas of the site covered by this SWPPP.
- RBI will provide copies of inspection reports to the other operators covered by this SWPPP within 24 hours following each inspection.
- RBI will be responsible for maintaining the cleanliness of the streets (Johnson Loop and Williams Avenue) and storm drain inlet protection Best Management Practices (BMPs) throughout the construction project. RBI will conduct street sweeping on a weekly basis and prior to forecasted rain events. RBI will also inspect and replace storm drain inlet protection BMPs as necessary.
- RBI will hold biweekly meetings to update operators on CGP compliance issues.
- RBI will maintain erosion and sediment control BMPs in all areas of the site under its day-to-day control.
- RBI will provide adequate designated concrete washout areas to all operators throughout the construction project and will be responsible for proper disposal of the concrete, mortar or grout collected there.

Homebuilders' Responsibilities:

- Costs incurred by RBI to address excess sediment discharges, debris or spills on roadways that result from an operator or subcontractor's negligence will be reimbursed by the responsible operator.
- If the operator or its subcontractor damages a storm drain inlet BMP, the operator will pay RBI \$200.00 for each inlet BMP that must be replaced.
- Operator shall not store erodible or hazardous materials on any roadway.
- Operator shall be responsible for maintaining compliance with the applicable SWPPP, including installation of erosion and sediment controls, within the individual lots under its day-to-day control. Any BMP changes that would trigger the need for a SWPPP modification shall be promptly communicated to RBI.
- Operator shall use the designated concrete washout area(s) provided by RBI to dispose of any excess concrete, mortar and grout.

Construction Operators' Cooperative Agreement

Joint Responsibilities:

- Each operator shall file a Notice of Intent (NOI) to be covered by the Construction General Permit before beginning construction at the project, and permit coverage will be maintained throughout the project.
- No operator shall file a Notice of Termination (NOT) until all disturbed areas of the site under its day-to-day control have been effectively stabilized with permanent erosion controls that satisfy the final stabilization requirement in the CGP; the only allowed exception is those areas that have been effectively stabilized with temporary erosion controls and turned over to a private landowner.
- Operators will maintain a clean site. Trash and debris will be picked up and disposed of properly by the end of each day.
- Each operator is responsible for advising employees and subcontractors working on this project of the requirements in the CGP and applicable SWPPP. Particular emphasis should be placed on ensuring that employees and subcontractors do not damage BMPs and do not introduce pollutants into the storm drain system.

The undersigned agree to abide by the terms and conditions of this cooperative agreement as described above.

RBI Development, Inc.
Operator

Doug Lewis
Signature

OWNER
Title

9/7/06
Date

In addition, I agree to comply with and be covered by RBI's SWPPP for this project.

I agree to the terms above, but choose to develop my own SWPPP rather than sign onto RBI's SWPPP for this project.

FALL HOMES, LLC
Operator Name

Drew Falls
Signature

OWNER
Title

9/7/06
Date

Project Manager(s) or Site Supervisor(s):

RBI Development, LLC
Mr. Jared Strong, Project Manager
13 South Avenue
Boise, ID 83701
Office Phone: (208) 555-5555
Site Phone: (208) 444-4444
Email: Jstrong@rbi.com

Mr. Strong is responsible for managing day-to-day site operations including overall site development of lots A1-C10 and construction of houses on lots A2–A16.

SWPPP Contact(s):

RBI Development, LLC
Ms. Dorothy Williams, Compliance/Inspection Officer
13 South Avenue
Boise, ID 83701
Office Phone: (208) 555-5555
Site Phone: (208) 444-4444
Email: Dwilliams@rbi.com

Ms. Williams is the primary SWPPP contact and responsible for compliance at the site, except lots B1-B9.

This SWPPP was Prepared by:

RBI Development, LLC
Ms. Dorothy Williams, Compliance/Inspection Officer
13 South Avenue
Boise, ID 83701
Office Phone: (208) 555-5555
Site Phone: (208) 444-4444

Emergency 24-Hour Contact:

RBI Development, LLC
Ms. Dorothy Williams, Compliance/Inspection Officer
Site Phone: (208) 444-4444
Cellular Phone: (208) 111-2222

SUBCONTRACTOR(S)	
Contact Information	Geographic Area of Control*
Mr. Carl Gooden, Owner Super Sweeping 345 Liberty Avenue Twin Falls, ID 83301 (208) 333-0987	Super Sweeping has entered into a contract with RBI Development to perform street sweeping for Williams Avenue and Johnson Loop.
Mrs. Julie Drake, Vice President Drake Waste and Sanitary Services 56 Washington Road Twin Falls, ID 83301 (208) 333-0044	Drake Waste and Sanitary Services have entered into a contract with RBI Development to deliver dumpsters and sanitary facilities to the site. They will also be responsible for dumpster and recycling waste pick up and disposal of sanitary wastes from the temporary sanitary facilities.
* See Appendix H – Subcontractor Certifications/Agreements	

SUBCONTRACTOR(S)	
Contact Information	Geographic Area of Control*
Mr. George Carl, Owner Future Foundations, LLC 78 Toms Road Twin Falls, ID 83301 (208) 333-7777	Future Foundations has entered into a contract with RBI Development and Coastal Creek Building to construct home foundations on lots A2-A16 and C1-C5. <i>AMENDMENT # 9 8/12/06 JS</i>
Mr. Greg Allen, Owner Poll Plumbing Company 234 Dunn Way Twin Falls, ID 83301 (208) 333-3333	Poll Plumbing Company has entered into a contract with RBI Development and Coastal Creek Building to install plumbing fixtures for individual housing lots. <i>AMENDMENT # 10 8/12/06 JS</i>
Mr. Michael Molds, Owner Molds Electric 6502 Capital Avenue Twin Falls, ID 83301 (208) 333-0000	Molds Electric has entered into a contract with RBI Development and Coastal Creek Building to install electrical components for individual housing lots. <i>AMENDMENT # 11 8/12/06 JS</i>
* See Appendix H – Subcontractor Certifications/Agreements	

1.3 Nature and Sequence of Construction Activity

Instructions:

- Briefly describe the nature of the construction activity and approximate time frames (one or more paragraphs, depending on the nature and complexity of the project).
- For more information, see *SWPPP Guide*, Chapter 3.A. and EPA's CGP Part 3, Subparts 3.3.B.1 and 2, and 3.4.A.

Describe the general scope of the work for the project, major phases of construction, etc:

RBI Development is planning to build a 20-acre residential subdivision at 2202 Williams Avenue, Stormville, Twin Falls County, Idaho. The subdivision will consist of 34 residential lots with paved road access. RBI Development is responsible for overall site development of lots A1–C10 including grading and infrastructure of these lots but only constructing houses on lots A2–A16. RBI Development has entered into contract to sell lots B1–B9 to Falls Homes and lots C1–C10 to Coastal Creek Building. Construction of houses will be on lots A2–A16, C1–C5 and B1–B9. Seven storm drain inlets, an earth dike, and a vegetated swale will be installed to convey runoff to a sediment basin. Soil disturbing activities will include: clearing and grubbing; installing stabilized construction exits; installing erosion and sediment controls; grading; excavation for the sediment basin, storm drain inlets, utilities, building foundations; construction of roads; and preparation for final seeding, mulching, and landscaping.

What is the function of the construction activity?

- Residential
 Commercial
 Industrial
 Road Construction
 Linear Utility
 Other (please specify):

Estimated Project Start Date: **05/05/2006**

Estimated Project Completion Date: **10/01/2008**

Table 1. Timeline of Activity: RBI Development will follow the sequence of activities below for major construction activities and BMP installation.

Estimated Timeline of Activity	Construction Activity and BMP Descriptions
05/05/2006 – 05/20/2006	<p><i>Before any grading activities begin</i></p> <ol style="list-style-type: none"> 1. Install orange colored plastic mesh fencing and mark trees to be preserved in areas identified on the site map as Preserve Existing Vegetation (Section 2, Part 2.1) 2. Install perimeter silt fences (Section 2, Part 2.7) 3. Construct stabilized construction exits for the site (Section 2, Part 2.9) 4. Begin clearing and grubbing, grading, and installation of access road for sediment basin (Section 2, Part 2.8) 5. Construct sediment basin (Section 2, Part 2.8)

05/20/2006 – 06/30/2006	<p>Site grading</p> <ol style="list-style-type: none"> 1. Begin site clearing and grubbing operations (Section 2, Part 2.2) 2. Construct vegetated swale (Section 2, Part 2.3) 3. Begin overall site grading and topsoil stripping (Section 2, Parts 2.1 and 2.2) 4. Establish topsoil stockpiles (Section 2, Part 2.1) 5. Install silt fences around the stockpiles and temporarily stabilize the stockpiles with erosion controls (Section 2, Part 2.1) 6. Disturbed areas where construction will cease for more than 14 days will be stabilized with erosion controls (Section 2, Part 2.4)
06/30/2006 – 09/15/2006	<p>Infrastructure (roads, utilities, etc.)</p> <ol style="list-style-type: none"> 1. Construct earth dike along upper portion of the North Slope (Section 2, Part 2.3) 2. Construct combined staging and materials storage area (Section 3, Part 3.2) 3. Establish hazardous materials storage area with the combined staging area (Section 3, Part 3.1) 4. Install temporary sanitary facilities (Section 3, Part 3.1) 5. Install dumpsters for the site (Section 3, Part 3.1) 6. Install utilities, sanitary sewers, and water services 7. Prepare pavement subgrade and install gutters, curbs, storm drain inlets, sewer manholes 8. Install silt fences at locations of all storm drain inlets on Johnson Loop (Section 2, Part 2.6)
09/15/2006 – 08/01/2008	<p>Home construction</p> <ol style="list-style-type: none"> 1. Construct temporary concrete washout areas (Section 3, Part 3.3) 2. Begin individual lot grading, and installation of utilities for individual lots 3. Permanently stabilize individual lots where housing is not planned (Section 2, Part 2.4) 4. Install stabilized construction exits for individual lots (Section 2, Part 2.9) 5. Install perimeter fiber rolls for individual housing lots A2-A16 (Section 2, Part 2.7) 6. Disturbed areas where construction will cease for more than 14 days will be stabilized with erosion controls (Section 2, Part 2.4) 7. Begin construction of housing foundations and houses
08/01/2008 – 10/01/2008	<p>Final stabilization</p> <ol style="list-style-type: none"> 1. Remove BMPs from storm drain inlets and finalize pavement activities. 2. Remove temporary concrete washout areas and restore to original grade (Section 2, Part 2.3) 3. Convert sediment basin to a permanent detention basin (Section 4) 4. Install storm drain inlet markers after pavement activities have been finalized (Section 4) 5. Remove all temporary control BMPs and stabilize any areas disturbed by there removal with erosion controls (Section 7) 6. Prepare final seeding and landscaping (Section 7) 7. Monitor stabilized areas until final stabilization is reached (Section 7)

Timeline of Activity: Coastal Creek Building will follow the sequence of activities below for major construction activities and BMP installation.

Estimated Timeline of Activity	Construction Activity and BMP Descriptions
09/15/2006 – 08/01/2008	<p>Home construction</p> <ol style="list-style-type: none"> 1. Begin individual lot grading, and installation of utilities for individual lots. 2. Permanently stabilize individual lots where housing is not planned. (Section 2, Part 2.4) 3. Install stabilized construction exits for individual lots. (Section 2, Part 2.9) 4. Install perimeter fiber rolls for individual housing lots. (Section 2, Part 2.7) 5. Disturbed areas where construction will cease for more than 14 days will be stabilized. (Section 2, Part 2.4) 6. Begin construction of housing foundations and houses.
08/01/2008 – 10/01/2008	<p>Final Stabilization</p> <ol style="list-style-type: none"> 1. Remove all erosion control measures and stabilize any areas disturbed by their removal with erosion controls. 2. Prepare final seeding and landscaping. (Section 7) 3. Monitor stabilized areas until final stabilization is reached. (Section 7)

1.4 Soils, Slopes, Vegetation, and Current Drainage Patterns

Instructions:

- Describe the existing soil conditions at the construction site including soil types, slopes and slope lengths, drainage patterns, and other topographic features that might affect erosion and sediment control.
- Also, note any historic site contamination evident from existing site features and known past usage of the site.
- This information should also be included on your site maps (See *SWPPP Guide*, Chapter 3.C.).
- For more information, see *SWPPP Guide*, Chapter 3.A and EPA's CGP Part 3, Subpart 3.3.C.

Soil type(s):

The current soil type of the site consists of gravely fine sand loam soil with bedrock subsoil.

Slopes (describe current slopes and note any changes due to grading or fill activities):

The north side of the site slopes down to Utah Creek and will remain as an area of natural vegetation and be protected during construction activities.

Drainage Patterns (describe current drainage patterns and note any changes due to grading or fill activities):

- Existing site runoff flows north toward Utah Creek and south toward an unnamed tributary of Utah Creek. (See Appendix B – Pre-Construction Site Map)
- After grading and installation of stormwater conveyances, ninety percent of the site runoff will be collected by storm drain inlets, an earth dike, and a vegetated swale, which will convey the runoff to the sediment basin in the northeast corner of the site. Water will be discharged from the sediment basin, through a riprap spillway and level spreader, and enter a natural vegetated area before discharging to Utah Creek. The remaining ten percent of site runoff will flow south and southwest to natural vegetated areas before discharging to an unnamed tributary of Utah Creek. (See Appendix B – Site Map)

Vegetation:

The site supports blocks of old growth trees (conifers) and undergrowth vegetation. Interspersed throughout the blocks of old-growth trees are open pasture lands. The open pasture lands are dominated by pasture grasses consisting of wheatgrass.

1.5 Construction Site Estimates

Instructions:

- Estimate the area to be disturbed by excavation, grading, or other construction activities, including dedicated off-site borrow and fill areas.
- Calculate the percentage of impervious surface area before and after construction
- Calculate the runoff coefficients before and after construction.
- For more information, see *SWPPP Guide*, Chapter 3.A and EPA's CGP Part 3, Subpart 3.3.B.

The following are estimates of the construction site:

Total project area:	20 acres
Construction site area to be disturbed:	18.5 acres
Percentage impervious area before construction:	10 %
Runoff coefficient before construction:	.07
Percentage impervious area after construction:	40 %
Runoff coefficient after construction:	.31

1.6 Receiving Waters

Instructions:

- List the waterbody(s) that would receive stormwater from your site, including streams, rivers, lakes, coastal waters, and wetlands. Describe each as clearly as possible, such as *Mill Creek, a tributary to the Potomac River*, and so on.
- Indicate the location of all waters, including wetlands, on the site map. For more information, see EPA's CGP Part 3, Subparts 3.3.B.4 and 3.3.C.6.
- Note any stream crossings, if applicable.
- List the storm sewer system or drainage system that stormwater from your site could discharge to and the waterbody(s) that it ultimately discharges to.
- If any of the waterbodies above are impaired and/or subject to Total Maximum Daily Loads (TMDLs), please list the pollutants causing the impairment and any specific requirements in the TMDL(s) that are applicable to construction sites. Your SWPPP should specifically include measures to prevent the discharge of these pollutants. For more information, see EPA's CGP Part 1, Subpart 1.3.C.5 and Part 3, Subpart 3.14.
- For more information, see *SWPPP Guide*, Chapter 3.A and 3.B.
- Also, for more information and a list of TMDL contacts and links by state, visit www.epa.gov/npdes/stormwater/tmdl.

Description of receiving waters:

Utah Creek has a reach of 43 miles running east to west through the Utah Valley and empties into the Pine River. Utah Creek is designated for the following uses under Idaho's Water Quality Standards (IDAPA 58.01.02): Secondary Contact Recreation, Agricultural Water Supply, and Wildlife Habitat. The unnamed tributary to Utah Creek has a reach of 11 miles and flows east to west and empties into Utah Creek 3 miles northwest of the construction site. Flows for the unnamed tributary vary during the wet and dry seasons.

Description of storm sewer systems:

The storm sewer system will be contained within the subdivision, and site runoff will be collected by storm drain inlets, an earth dike, and a vegetated swale, which will convey the runoff to the sediment basin in the northeast corner of the site. Water will then be discharged from the sediment basin, through a riprap spillway and level spreader and enter a natural vegetated area before discharging to Utah Creek. The earth dike and vegetated swale will remain as permanent stormwater management structures after construction activities are completed. The sediment basin will be converted to a permanent detention basin during the final stabilization phase of construction and function as a stormwater management structure.

Description of impaired waters or waters subject to TMDLs:

RBI Development conducted a review of Utah Creek and the unnamed tributary to determine if the waters were impaired or subject to TMDLs. RBI first reviewed the 1998 303(d) list for the state of Idaho available at http://www.deq.state.id.us/water/data_reports/surface_water/monitoring/1998_303d_list_chap2_entire.pdf (accessed 10/17/05). RBI did not identify Utah Creek or the unnamed tributary as impaired waters or subject to TMDLs.

To verify that Utah Creek and the unnamed tributary are not impaired waters or subject to TMDLs, RBI contacted Balthasar Buhidar with the Department of Environmental Quality, Twin Falls Regional Office. RBI described the project location and receiving waters during the conversation on 10/18/2005 (See Appendix L – Telephone Log #2). Mr. Buhidar verified during the telephone call that Utah Creek and the unnamed tributary are not impaired waters or subject to TMDLs.

1.7 Site Features and Sensitive Areas to be Protected

Instructions:

- Describe unique site features including streams, stream buffers, wetlands, specimen trees, natural vegetation, steep slopes, or highly erodible soils that are to be preserved.
- Describe measures to protect these features.
- Include these features and areas on your site maps.
- For more information, see *SWPPP Guide*, Chapter 3.A and 3.B.

Description of unique features that are to be preserved:

Existing vegetation consisting of old-growth trees (conifers) and undergrowth vegetation, surrounding the proposed project area will be preserved during site construction. A portion of the construction will disturb a small portion of the existing vegetation to install the riprap spillway and level spreader for the sediment basin.

Describe measures to protect these features:

The existing vegetation will be protected during construction activities as described in Section 2, Part 2.1.

1.8 Potential Sources of Pollution

Instructions:

- Identify and list all potential sources of sediment, which may reasonably be expected to affect the quality of stormwater discharges from the construction site.
- Identify and list all potential sources of pollution, other than sediment, which may reasonably be expected to affect the quality of stormwater discharges from the construction site.
- For more information, see *SWPPP Guide*, Chapter 3.A and EPA's CGP Part 3, Subpart 3.1.B.

Potential sources of sediment to stormwater runoff:

- Clearing and grubbing operations
- Grading and site excavation operations
- Vehicle tracking
- Topsoil stripping and stockpiling
- Landscaping operations

Potential pollutants and sources, other than sediment, to stormwater runoff:

- Combined Staging Area—small fueling activities, minor equipment maintenance, sanitary facilities, and hazardous waste storage.
- Materials Storage Area—general building materials, solvents, adhesives, paving materials, paints, aggregates, trash, etc.
- Construction Activity—paving, curb/gutter installation, concrete pouring/mortar/stucco, and building construction
- Concrete Washout Area

For all potential construction site pollutants, see Table 2 below.

Table 2. Potential construction site pollutants

Material/Chemical	Physical Description	Stormwater Pollutants	Location*
Pesticides (insecticides, fungicides, herbicides, rodenticides)	Various colored to colorless liquid, powder, pellets, or grains	Chlorinated hydrocarbons, organophosphates, carbamates, arsenic	Herbicides used for noxious weed control
Fertilizer	Liquid or solid grains	Nitrogen, phosphorous	Newly seeded areas
Plaster	White granules or powder	Calcium sulphate, calcium carbonate, sulfuric acid	Home construction
Cleaning solvents	Colorless, blue, or yellow-green liquid	Perchloroethylene, methylene chloride, trichloroethylene, petroleum distillates	No equipment cleaning allowed in project limits
Asphalt	Black solid	Oil, petroleum distillates	Streets and roofing
Concrete	White solid/grey liquid	Limestone, sand, pH, chromium	Curb and gutter, building construction
Glue, adhesives	White or yellow liquid	Polymers, epoxies	Home construction
Paints	Various colored liquid	Metal oxides, stoddard solvent, talc, calcium carbonate, arsenic	Home construction
Curing compounds	Creamy white liquid	Naphtha	Curb and gutter
Wood preservatives	Clear amber or dark brown liquid	Stoddard solvent, petroleum distillates, arsenic, copper, chromium	Timber pads and Home construction
Hydraulic oil/fluids	Brown oily petroleum hydrocarbon	Mineral oil	Leaks or broken hoses from equipment
Gasoline	Colorless, pale brown or pink petroleum hydrocarbon	Benzene, ethyl benzene, toluene, xylene, MTBE	Secondary containment/staging area
Diesel Fuel	Clear, blue-green to yellow liquid	Petroleum distillate, oil & grease, naphthalene, xylenes	Secondary containment/staging area
Kerosene	Pale yellow liquid petroleum hydrocarbon	Coal oil, petroleum distillates	Secondary containment/staging area

Material/Chemical	Physical Description	Stormwater Pollutants	Location*
Antifreeze/coolant	Clear green/yellow liquid	Ethylene glycol, propylene glycol, heavy metals (copper, lead, zinc)	Leaks or broken hoses from equipment
Sanitary toilets	Various colored liquid	Bacteria, parasites, and viruses	Staging area

*(Area where material/chemical is used on-site)

1.9 Endangered Species Certification

Instructions:

- Before beginning construction, determine whether endangered or threatened species or their critical habitats are on or near your site.
- Adapt this section as needed for state or tribal endangered species requirements and, if applicable, document any measures deemed necessary to protect endangered or threatened species or their critical habitats.
- For more information on this topic, see *SWPPP Guide*, Chapter 3.B and EPA's CGP Part 1, Subpart 1.3.C.6 and Appendix C.
- Additional information on Endangered Species Act (ESA) provisions for EPA's Construction General Permit is at www.epa.gov/npdes/stormwater/esa

Are endangered or threatened species and critical habitats on or near the project area?

Yes No

Describe how this determination was made:

Ms. Williams conducted a review of any potential endangered/threatened species and critical habitat on or near the Clover Hills Subdivision project in Twin Falls County, Idaho. RBI first reviewed the Endangered Species Act (ESA) review procedures and endangered species list for Idaho available at <http://cfpub.epa.gov/npdes/stormwater/esa.cfm> (accessed on 10/15/05). RBI did not identify any endangered species in the project area.

Ms. Williams then reviewed information available from the Idaho Governor's Office of Species Conservation at <http://species.idaho.gov/index.html> (accessed on 10/16/05). To verify that there were no endangered species within the project area; Ms. Williams contacted Nate Fisher with the Office of Species Conservation on 10/17/05 (See Appendix L – Telephone Log #1). Ms. Williams described the location of the construction project and the closest receiving waters (Utah Creek and the unnamed tributary to Utah Creek). Mr. Fisher verified in the telephone call that there were no endangered/threatened species or critical habitats in the immediate project area.

Because no endangered or threatened species or their critical habitats were found during the screening process, Criterion A will be reported on the NOI form.

If yes, describe the species and/or critical habitat:

N/A

If yes, describe or refer to documentation that determines the likelihood of an impact on identified species and/or habitat and the steps taken to address that impact. (Note, if species are on or near your project site, EPA strongly recommends that the site operator work closely with the appropriate field office of the U.S. Fish and Wildlife Service or National Marine Fisheries Service. For concerns related to state or tribal listing of species, please contact a state or tribal official.)

N/A

1.10 Historic Preservation

Instructions:

- Before you begin construction, you should review federal and any applicable state, local, or tribal historic preservation laws and determine if there are historic sites on or near your project. If so, you might need to make adjustments to your construction plans or to your stormwater controls to ensure that these historic sites are not damaged.
- For more information, see *SWPPP Guide*, Chapter 3.B or contact your state or tribal historic preservation officer.

Are there any historic sites on or near the construction site?

Yes No

Describe how this determination was made:

Ms. Williams reviewed the Idaho State Register of Historic Places available from the Idaho State Preservation Office at <http://www.idahohistory.net/shpo> (accessed on 10/17/05) and the National Register Information System available from the National Park Service at <http://www.nr.nps.gov/> (accessed on 10/17/05) to determine if any historic sites are on or near the Clover Hills Subdivision. No historic sites were identified from the review.

To verify that there were no historic sites on or near the project area, Ms. Williams contacted Janet Gallimore, State Historic Preservation Officer, of the Idaho State Preservation Office on 10/17/05 (See Appendix L – Telephone Log #3). Ms. Williams described the location of the project, and Mrs. Gallimore verified in the telephone call that there were no historic sites on or near the project area.

If yes, describe or refer to documentation that determines the likelihood of an impact on this historic site and the steps taken to address that impact.

N/A

1.11 *Applicable Federal, Tribal, State or Local Programs*

Instructions:

- Note other applicable federal, tribal, state or local soil and erosion control and stormwater management requirements that apply to the construction site. See EPA's CGP Part 3.9.

The Twin Falls County Stormwater Ordinance specifies design requirements for the sediment basin and stabilized construction exits for residential lots.

- The Twin Falls County's stormwater ordinance (Ch. 10.3) requires the design volume of the sediment basin be based on the following calculation:

$$\text{Design Volume} = 3,600 \text{ cubic feet} \times \text{Area}$$

$$\text{Design Volume} = (3,600 \text{ cu ft/acre}) \times 20 \text{ acres} = 72,000 \text{ cubic feet}$$

- The Twin Falls County's stormwater ordinance (Ch. 20.1) specifies that stabilized construction exits for residential lots will have a minimum length of 30 feet.

1.12 *Maps*

Instructions:

- Attach site maps. For most projects, a series of site maps is recommended. The first should show the undeveloped site and its current features. An additional map or maps should be created to show the developed site or for more complicated sites show the major phases of development.

These maps should include the following:

- Direction(s) of stormwater flow and approximate slopes before and after major grading activities;
- Areas and timing of soil disturbance;
- Areas that will not be disturbed;
- Natural features to be preserved;
- Locations of major structural and non-structural BMPs identified in the SWPPP;
- Locations and timing of stabilization measures;
- Locations of off-site material, waste, borrow, or equipment storage areas;
- Locations of all waters, including wetlands;
- Locations where stormwater discharges to a surface water;
- Locations of storm drain inlets; and
- Areas where final stabilization has been accomplished.
- For more information, see SWPPP Guide, Chapter 3.C and EPA's CGP Part 3, Subparts 3.1.B.1 and 3.3.C.

See Appendix B – Site Maps

SECTION 2: EROSION AND SEDIMENT CONTROL BMPs

Instructions:

- Describe the BMPs that will be implemented to control pollutants in stormwater discharges. For each major activity identified, do the following
 - ✓ Clearly describe appropriate control measures.
 - ✓ Describe the general sequence during the construction process in which the measures will be implemented.
 - ✓ Describe the maintenance and inspection procedures that will be used for that specific BMP.
 - ✓ Include protocols, thresholds, and schedules for cleaning, repairing, or replacing damaged or failing BMPs.
 - ✓ Identify staff responsible for maintaining BMPs.
 - ✓ (If your SWPPP is shared by multiple operators, indicate the operator responsible for each BMP.)
- Categorize each BMP under one of the following 10 areas of BMP activity as described below:
 - 2.1 *Minimize disturbed area and protect natural features and soil*
 - 2.2 *Phase Construction Activity*
 - 2.3 *Control Stormwater flowing onto and through the project*
 - 2.4 *Stabilize Soils*
 - 2.5 *Protect Slopes*
 - 2.6 *Protect Storm Drain Inlets*
 - 2.7 *Establish Perimeter Controls and Sediment Barriers*
 - 2.8 *Retain Sediment On-Site and Control Dewatering Practices*
 - 2.9 *Establish Stabilized Construction Exits*
 - 2.10 *Any Additional BMPs*
- Note the location of each BMP on your site map(s).
- For any structural BMPs, you should provide design specifications and details and refer to them. Attach them as appendices to the SWPPP or within the text of the SWPPP.
- For more information, see *SWPPP Guide*, Chapter 4 and EPA's CGP Part 3, Subparts 3.3.B.2 and 3.4.A-D, and Part 4, Subpart 4.5.
- Consult your state's design manual or one of those listed in Appendix D of the *SWPPP Guide*.
- For more information or ideas on BMPs, see EPA's National Menu of BMPs
<http://www.epa.gov/npdes/stormwater/menuofbmps>

2.1 Minimize Disturbed Area and Protect Natural Features and Soil

Instructions:

- Describe the areas that will be disturbed with each phase of construction and the methods (e.g., signs, fences) that you will use to protect those areas that should not be disturbed. Describe natural features identified earlier and how each will be protected during construction activity. Also describe how topsoil will be preserved. Include these areas and associated BMPs on your site map(s) also. (For more information, see *SWPPP Guide*, Chapter 4, ESC Principle 1.)
- Also, see EPA's *Preserving Natural Vegetation BMP Fact Sheet* at www.epa.gov/npdes/stormwater/menuofbmps/construction/preserve_veg

Existing Vegetation

BMP Description: The preserved area of existing vegetation, as identified on the site map, will be surrounded by a temporary orange colored plastic mesh fence and all trees on the perimeter of the protected area will be marked with a brightly colored ribbon. The fencing will be at least 3 feet tall and have openings not larger than 2 inches by 2 inches. Support posts for the temporary fence will be a minimum of 4.5 feet and driven a minimum of 18 to 20 inches in the ground. Posts will be spaced a maximum of 6 feet apart. The temporary fencing will be installed at the drip/spread line of the trees and undergrowth vegetation to be protected. Vehicles and equipment will be kept away from the protected area.

Installation Schedule:	The preserved area of existing vegetation will be surrounded with the orange-colored plastic mesh fence, and trees will be marked before construction begins at the site.
Maintenance and Inspection:	The area will be inspected weekly to ensure the temporary fence is intact and the trees are clearly marked. During construction, preserved areas of existing vegetation will be surrounded by the orange-colored mesh fence and clearly marked at all times.
Responsible Staff:	RBI Development

Topsoil

BMP Description: Topsoil stripped from the immediate construction area will be stockpiled as identified on the site map (See Appendix B). The stockpiles will be in areas that will not interfere with construction phases and at least 15 feet away from areas of concentrated flows or pavement. The slopes of the stockpile will be roughened by equipment tracking and will not exceed 2:1 to prevent erosion. A silt fence will be installed around the perimeter of each stockpile, in accordance with the silt fence design specifications in Section 2, Part 2.7. Stockpiles will also be temporarily stabilized with erosion controls as described in Section 2, Part 2.4.

Installation Schedule:	Topsoil stockpiles will be established during grading activities. The silt fence and temporary erosion controls will be installed immediately after the stockpile has been established.
-------------------------------	-----------------------------------------------------------------------------------------------------------------------------------------------------------------------------------------

<i>Maintenance and Inspection:</i>	The area will be inspected weekly for erosion and immediately after storm events. Areas on or around the stockpile that have eroded will be stabilized immediately with erosion controls. Maintenance and inspection procedures for the silt fence are described in Section 2, Part 2.7.
<i>Responsible Staff:</i>	RBI Development

2.2 Phase Construction Activity

Instructions:

- Describe the intended construction sequencing and timing of major activities, including any opportunities for phasing grading and stabilization activities to minimize the overall amount of disturbed soil that will be subject to potential erosion at one time. Also, describe opportunities for timing grading and stabilization so that all or a majority of the soil disturbance occurs during a time of year with less erosion potential (i.e., during the dry or less windy season). (For more information, see *SWPPP Guide*, Chapter 4, ESC Principle 2.) It might be useful to develop a separate, detailed site map for each phase of construction.
- Also, see EPA's *Construction Sequencing BMP Fact Sheet* at http://www.epa.gov/npdes/stormwater/menuofbmps/construction/cons_seq

BMP Description: Because of the relatively small project area (20 acres) and the need to grade and install roads before building construction begins, it is not practical to perform phased grading at this site. To minimize potential erosion, only areas necessary to construct the construction exits, access road for the sediment basin and the sediment basin will be disturbed initially. These areas will be cleared, grubbed, and graded and the construction exits, access road and sediment basin will be installed. These areas will be stabilized with erosion controls immediately after construction but no later than 14 days after construction. Overall grubbing, clearing, and grading is planned to occur in late May and June during a time of the year with less rainfall to limit erosion from the site. Areas disturbed during this period will be stabilized with hydromulch or other erosion controls immediately after construction but no later than 14 days after construction ceases (see Section 2, Part 2.4).

<i>Installation Schedule:</i>	For a timeline of construction activity, see Section 1.3.
<i>Responsible Staff:</i>	RBI Development

2.3 Control Stormwater Flowing onto and through the Project

Instructions:

- Describe structural practices (e.g., diversions, berms, ditches, storage basins) including design specifications and details used to divert flows from exposed soils, retain or detain flows, or otherwise limit runoff and the discharge of pollutants from exposed areas of the site. (For more information, see *SWPPP Guide*, Chapter 4, ESC Principle 3.)

Earth Dike

BMP Description: A permanent earth dike will be constructed horizontally along the uphill perimeter of the northern slope, as detailed on the site map, to convey stormwater to the sediment basin. The dike will be constructed of compacted soil and have a top width of 4 feet, a height of 2 feet and 2:1 side slopes. A stabilized channel (1 foot in depth and 3 feet wide) will be installed at the bottom of the uphill side of the dike to convey runoff to the sediment basin. A riprap spillway will be installed in the channel to dissipate water velocity before discharging to the sediment basin. The dike will be permanently stabilized by hydroseeding and mulching to prevent erosion and damage immediately after construction. The earth dike will remain as a permanent stormwater structure after construction is complete. For design specifications, see Figure 1.

Installation Schedule:	The dike and channel will be installed before infrastructure construction begins at the site.
Maintenance and Inspection:	The dike will be inspected weekly and after storm events for erosion damage and structural failures. The dike will be maintained at its original height and repaired if the original height decreases. If seeding and mulching fails or is washed away, the dike will be reseeded and re-mulched. Any erosion damage or structural failures will be repaired immediately. Accumulated sediments will be removed from the channel when one-third of the height of the channel is reached. Removed sediments will be hauled off-site for disposal at Springfield Landfill.
Responsible Staff:	RBI Development

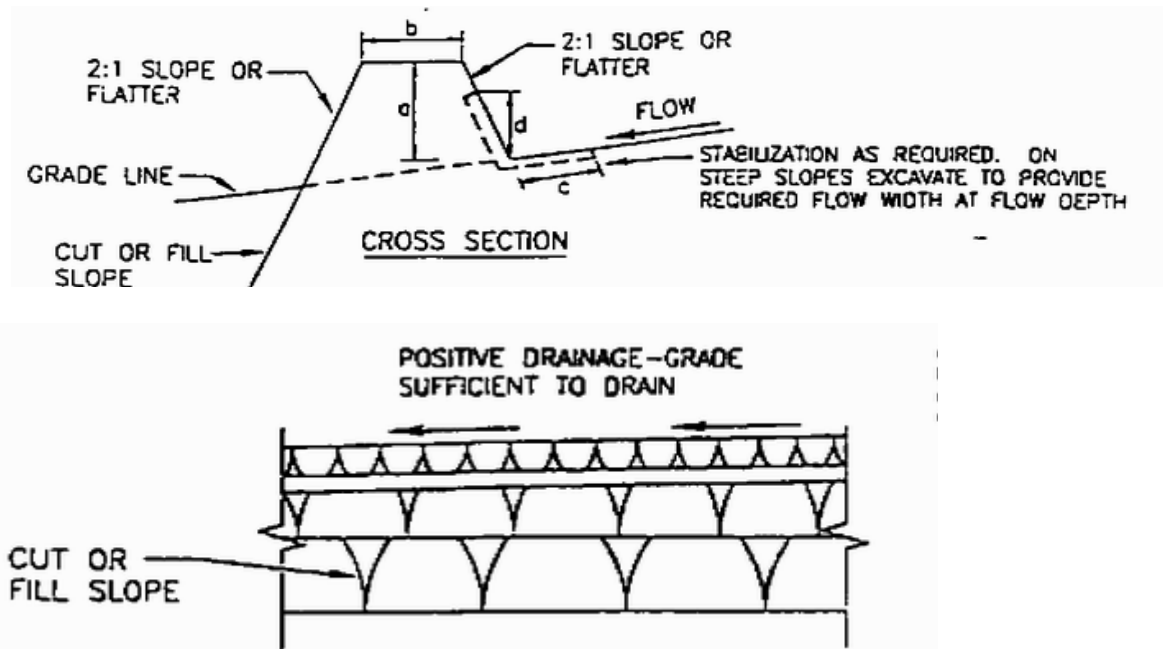

Figure 1. Earth dike

Design Specifications

1. The earth dike will be compacted by earth-moving equipment.
2. The earth dike will have positive drainage.
3. The earth dike will have a width of 4 feet, a height of 2 feet, and 2:1 side slopes.
4. A stabilized channel (1 foot in depth and 3 feet wide) will be installed at the uphill side of the earth dike to convey runoff to the sediment basin.

Vegetated Swale

BMP Description: A vegetated swale will be installed between housing lots B1-B8 and B9-A16, as detailed on the site map. The swale will convey runoff to a storm drain inlet, southwest of lot A12. The swale will have side slopes (2:1), and the slopes and bottom of the swale will be seeded, mulched, and stabilized using erosion control blankets to allow vegetation to be established. Fiber roll check dams will be installed along the vegetated swale. The rolls will consist of rolled tubes of erosion control blankets (8 inches in diameter) and bound at each end with jute-type twine. The rolls will be placed along the swale in 6-foot intervals and staked into the ground using wooden stakes (24 inches long) 3 feet apart. The vegetated swale will remain as a permanent stormwater structure after construction is complete. For design specifications, see Figure 2.

Installation Schedule:

The vegetated swale will be installed after clearing and grubbing operations are completed at the site.

<i>Maintenance and Inspection:</i>	The swale will be inspected weekly and immediately after storm events for erosion and structural failures. Before vegetation has been established in the swale, inspect erosion control blankets, embankments, and beds for erosion and accumulation of debris and sediment. Remove debris, sediment, and repair erosion control blankets, fiber rolls and embankments immediately.
<i>Responsible Staff:</i>	RBI Development

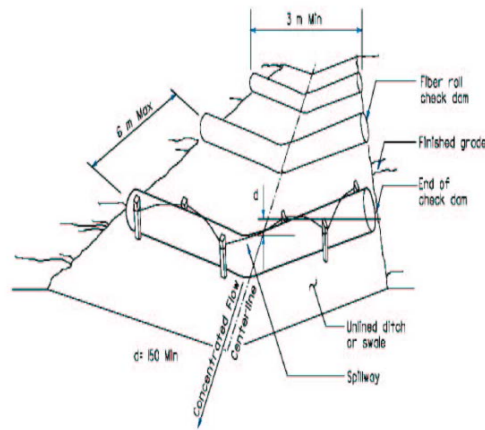
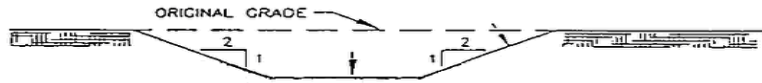

Figure 2. Vegetated swale

Design Specifications

1. The swale will have side slopes of 2:1.
2. The channel will be lined with erosion control blankets.
3. Fiber roll check dams will be placed along the swale in 6-foot intervals.
4. The swale will have a positive drainage to convey runoff to the storm drain inlet.

2.4 Stabilize Soils

Instructions:

- Describe controls (e.g., interim seeding with native vegetation, hydroseeding) to stabilize exposed soils where construction activities have temporarily or permanently ceased. Also describe measures to control dust generation. Avoid using impervious surfaces for stabilization whenever possible. (For more information, see *SWPPP Guide*, Chapter 4, ESC Principle 4, EPA's CGP Part 3, Subpart 3.13.D.)
- Also, see EPA's *Seeding BMP Fact Sheet* at www.epa.gov/npdes/stormwater/menuofbmps/construction/seeding

Temporary Stabilization

BMP Description: Temporary vegetative cover will be established using hydroseeding for areas of exposed soil (including stockpiles) where construction will cease for more than 14 days and seeded surfaces. Hydroseeding will consist of wood fibers, seed (Smooth Brome), fertilizer, and stabilizing emulsion and applied at a rate of 8 pounds per acre. Seeding will be conducted during periods of the year when vegetation is more likely to be established.

Permanent

Temporary

Installation Schedule:	Temporary stabilization measures will be applied to portions of the site where construction activities will temporarily cease for more than 14 days.
Maintenance and Inspection:	Stabilized areas will be inspected weekly and after storm events until a dense cover of vegetation has become established. If failure is noticed at the seeded area, the area will be reseeded, fertilized, and mulched immediately.
Responsible Staff:	RBI Development / COASTAL CREEK BUILDING

Mulching

BMP Description: Hydromulching will provide immediate protection to exposed soils during short periods of construction. Hydromulch will also be applied in areas that have been seeded for temporary or permanent stabilization. Straw mulch and wood fibers will be mixed with a tackifier (amount specified per manufacturer's instructions) and applied uniformly by machine with an application rate of 90–100 pounds (2–3 bales) per 1,000 square feet or 2 tons (100–200 bales) per acre. If the tackifier does not appear effective in anchoring the mulch to the disturbed soil, crimping equipment will be used to provide additional binding to the soil. The mulch will cover 75 to 90 percent of the ground surface.

Installation Schedule:	Hydromulch will be applied to exposed soils during short periods of construction and seeded areas.
Maintenance and Inspection:	Mulched areas will be inspected weekly and after storm events to check for movement of mulch or erosion. If washout, breakage, or erosion occurs, the surface will be repaired, and new mulch will be applied to the damaged area.
Responsible Staff:	RBI Development / COASTAL CREEK BUILDING

Permanent Stabilization

BMP Description: Permanent stabilization will be done immediately after the final design grades are achieved but no later than 14 days after construction ceases. Native species of plants will be used to establish vegetative cover on exposed soils. Permanent stabilization will be completed in accordance with the final stabilization procedures in Section 7.

Permanent **Temporary**

Installation Schedule:	Portions of the site where construction activities have permanently ceased will be stabilized, as soon as possible but no later than 14 days after construction ceases.
Maintenance and Inspection:	All seeded areas will be inspected weekly during construction activities for failure and after storm events until a dense cover of vegetation has been established. If failure is noticed at the seeded area, the area will be reseeded, fertilized, and mulched immediately. After construction is completed at the site, permanently stabilized areas will be monitored until final stabilization is reached.
Responsible Staff:	RBI Development / COASTAL CREEK BUILDING

Dust Control

BMP Description: Dust from the site will be controlled by using a mobile pressure-type distributor truck to apply potable water to disturbed areas. The mobile unit will apply water at a rate of 300 gallons per acre and minimized as necessary to prevent runoff and ponding.

Installation Schedule:	Dust control will be implemented as needed once site grading has been initiated and during windy conditions (forecasted or actual wind conditions of 20 mph or greater) while site grading is occurring. Spraying of potable water will be performed no more than three times a day during the months of May–September and once per day during the months of October–April or whenever the dryness of the soil warrants it.
Maintenance and Inspection:	At least one mobile unit will be available at all times to distribute potable water to control dust on the project area. Each mobile unit will be equipped with a positive shutoff valve to prevent over watering of the disturbed area. For vehicle and equipment maintenance practices, see Section 3, Part 3.4.
Responsible Staff:	RBI Development

2.5 Protect Slopes

Instructions:

- Describe controls (e.g., erosion control blankets, tackifiers) including design specifications and details that will be implemented to protect all slopes. (For more information, see *SWPPP Guide*, Chapter 4, ESC Principle 5.)
- Also, see EPA’s *Geotextiles BMP Fact Sheet* at www.epa.gov/npdes/stormwater/menuofbmps/construction/geotextiles

Geotextile Erosion Control Blanket

BMP Description: Geotextile erosion control blankets will be used to provide stabilization for the slopes in the vegetated swale and sediment basin. The blanket will cover the entire area of the graded slope and bottom channel. The bottom and side slopes will be seeded and mulched before the blanket is applied. The blanket will be installed by digging a small trench on the upside of the slope, 12 inches wide by 6 inches deep, and stapling the leading edge of the blanket in the trench. The blanket will be rolled down the slope slowly to maintain soil contact and stapled in 12-inch intervals. If the blanket cannot cover the entire slope, the blankets will be overlapped (minimum of 2 inches) and stapled at the overlapped edge. The erosion control blanket will always be installed according to the manufacturer’s instructions and specifications. For design specifications, see Figure 3.

Installation Schedule:	The erosion control blankets will be installed once the slopes of the vegetated swale and sediment basin have reached final grade.
Maintenance and Inspection:	The erosion control blanket will be inspected weekly and immediately after storm events to determine if cracks, tears, or breaches have formed in the fabric; if so, the blanket will be repaired or replaced immediately. Good contact with the soil will be maintained and erosion will not occur under the blanket. Any areas where the blanket is not in close contact with the ground will be repaired or replaced.
Responsible Staff:	RBI Development

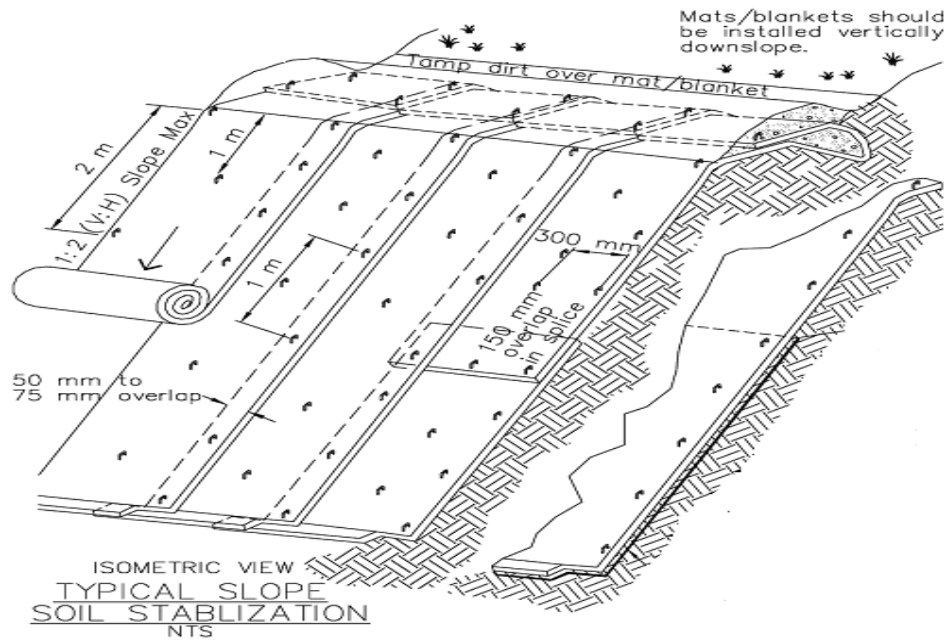

Figure 3. Erosion control blanket

Design Specifications

1. Slope surface will be free of rocks, clods, sticks and grass. The blankets will have good soil contact.
2. Lay blankets loosely and staple to maintain direct contact with the soil. Do not stretch.
3. Install per manufacturer's recommendations.

2.6 Protect Storm Drain Inlets

Instructions:

- Describe controls (e.g., inserts, rock-filled bags, or block and gravel) including design specifications and details that will be implemented to protect all inlets receiving stormwater from the project during the entire project. (For more information, see *SWPPP Guide*, Chapter 4, ESC Principle 6.)
- Also, see EPA’s *Storm Drain Inlet Protection BMP Fact Sheet* at www.epa.gov/npdes/stormwater/menuofbmps/construction/storm_drain

Storm Drain Inlet in the Vegetated Swale

BMP Description: Fiber rolls will be installed around the perimeter of the storm drain inlet (see inset 1 site map). The rolls will consist of rolled tubes of erosion control blankets (8 inches in diameter) and bound at each end with jute-type twine. The rolls will be installed in shallow trenches dug 2–4 inches below ground surface and staked into the ground using wooden stake (24 inches long) 3 to 4 feet apart. For design specifications of fiber rolls, see Section 2, Part 2.7.

Installation Schedule:	The fiber rolls and check dams will be installed once the swale has erosion control blankets in place and has been stabilized.
Maintenance and Inspection:	The fiber rolls will be inspected weekly and immediately after storm events to replace or repair split, torn, unraveled or slumping rolls. Accumulated sediment will be removed when accumulation reaches one-third the height of the fiber roll. The removed sediment will be hauled off-site and disposed of at Springfield Landfill.
Responsible Staff:	RBI Development

Storm Drain Inlet Protection before Paving

BMP Description: A silt fence barrier will be constructed around all storm drain inlets except the storm drain inlet in the vegetated swale. The silt fence barrier will be installed by excavating a 12-inch-deep trench around the storm drain inlet. Wooden posts supporting the silt fence will be spaced 2 to 3 feet apart and driven securely into the ground; a minimum of 18 to 20 inches deep. The bottom edge of the silt fence will extend across the bottom of the trench and the trench will be backfilled and compacted to prevent stormwater and sediment from discharging underneath the silt fence. For design specifications, see Figure 4.

Installation Schedule:	Once the storm drain inlets have been installed on-site, the silt fences will be immediately placed around the inlets. The sediment fences surrounding the six storm drain inlets on the main road will be removed and replaced with gravel bag barriers once the pavement subgrade has been applied.
Maintenance and Inspection:	For maintenance and inspection procedures for the silt fence, see Section 2, Part 2.7.
Responsible Staff:	RBI Development

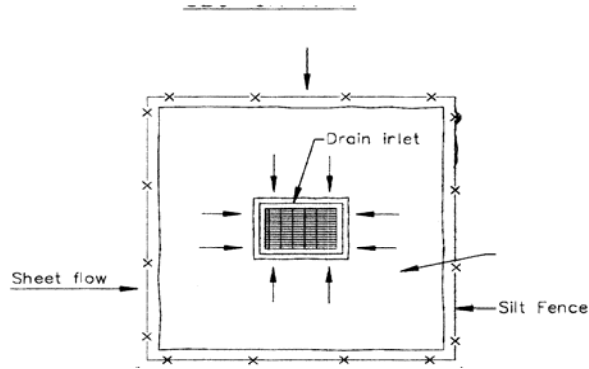

Figure 4. Silt fence storm drain inlet protection

Design Specifications

1. The silt fence will be constructed long enough to extend across the expected flow path.
2. The support posts will be a minimum of 4.5 feet and driven a minimum of 18 to 20 inches in the ground. Posts will be spaced a maximum of 6 feet apart. Fabric will be securely fastened to posts with half-inch staples or 16-gauge wire ties spaced a maximum of 6 inches.
3. A 12-inch trench will be excavated along the uphill side of the silt fence posts. The bottom edge of the fabric will extend across the bottom of the trench. The trench will be backfilled to 4 inches above ground and compacted to bury and secure the bottom of the filter fabric

Storm Drain inlet protection after Road Paving

BMP Description: Gravel bag barriers made of woven geotextile fabric will be installed around the six storm drain inlets on Johnson Loop. The barriers will be installed at minimum height of two bags and maintain a spillway with a height of one bag. For design specifications, see Figure 5.

Installation Schedule:	The barriers will be installed around the six inlets along the road once the pavement subgrade has been applied. The gravel bag barriers will be removed before final pavement activities begin.
Maintenance and Inspection:	Inspect all barriers weekly and immediately after storm events for holes, tears, and snags. Check gravel bags for proper arrangement and displacement. Remove accumulated sediment when it reaches one-third the height of the barrier. Removed sediments will be hauled off-site to Springfield Landfill. Make repairs immediately to the fabric barrier if the barrier has been damaged. The anticipated life span of the gravel bag barriers is 3 months and will likely need to be replaced after this time span.
Responsible Staff:	RBI Development

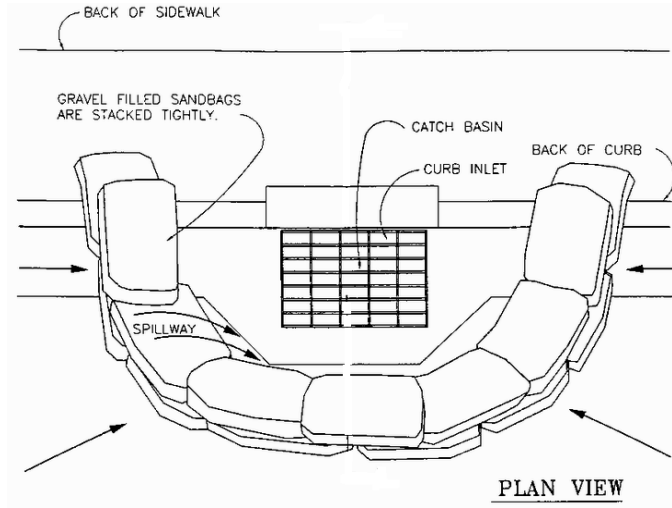

Figure 5. Gravel bag barriers

Design Specifications

1. Place gravel bag barriers around the storm drain inlets where water can pond and allow sediment to separate from runoff.
2. Bags of woven geotextile fabric will be filled with gravel, layered, and packed tightly.
3. Leave one gravel bag gap in the top row to provide a spillway for overflow.

2.7 Establish Perimeter Controls and Sediment Barriers

Instructions:

- Describe structural practices (e.g., silt fences or fiber rolls) including design specifications and details to filter and trap sediment before it leaves the construction site. (For more information, see *SWPPP Guide*, Chapter 4, ESC Principle 7.)
- Also see, EPA’s *Silt Fence BMP Fact Sheet* at www.epa.gov/npdes/stormwater/menuofbmps/construction/silt_fences or *Fiber Rolls BMP Fact Sheet* at www.epa.gov/npdes/stormwater/menuofbmps/construction/fiber_rolls

Silt Fence

BMP Description: Silt fences will be installed around the perimeter of the entire site, except at the two construction entrances. A silt fence will also be installed around the topsoil stockpile. Silt fences will be installed by excavating a 12-inch-deep trench along the line of proposed installation. Wooden posts supporting the silt fence will be spaced 4 to 6 feet apart and driven securely into the ground; a minimum of 18 to 20 inches deep. The silt fence will be fastened securely to the wooden posts with wire ties spaced every 24 inches at the top, mid section, and bottom of the wooden post. The bottom edge of the silt fence will extend across the bottom of the trench and the trench will be backfilled and compacted to prevent stormwater and sediment from discharging underneath the silt fence. For design specifications, see Figure 6.

Installation Schedule:	The silt fences will be installed before construction begins at the site and around topsoil stockpiles once they have been established.
Maintenance and Inspection:	Silt fences will be inspected weekly and immediately after storm events to ensure it is intact and that there are no gaps where the fence meets the ground or tears along the length of the fence. If gaps or tears are found during the inspection, the fabric will be repaired or replaced immediately. Accumulated sediment will be removed from the fence base if it reaches one-third the height of the silt fence and hauled off-site for disposal at Springfield Landfill. If accumulated sediment is creating noticeable strain on the fabric and the fence might fail from a sudden storm event, the sediment will be removed more frequently. Before the fence is removed from the project area, the sediment will be removed. The anticipated life span of the silt fence is 6 months and will likely need to be replaced after this period.
Responsible Staff:	RBI Development

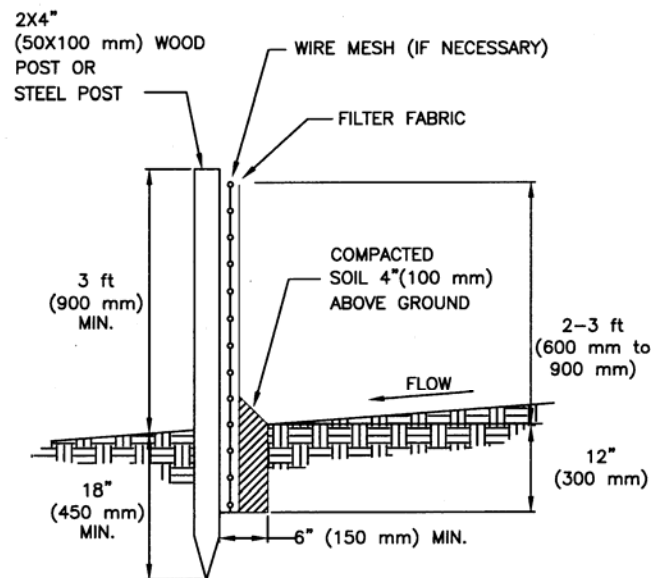
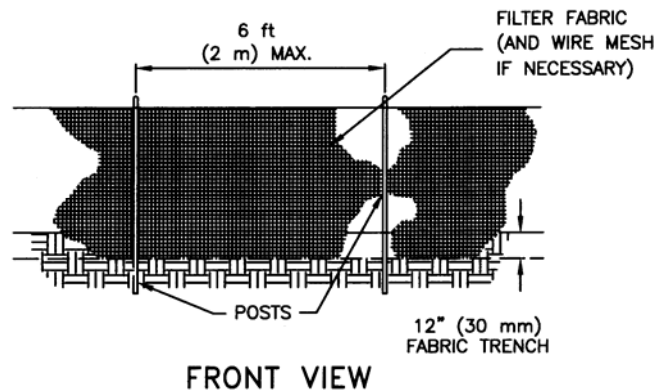

Figure 6. Silt fence

Design Specifications

1. The silt fence will be constructed long enough to extend across the expected flow path.
2. The support posts will be a minimum of 4.5 feet and driven a minimum of 18 to 20 inches in the ground. Posts will be spaced a maximum of 6 feet apart. Fabric will be securely fastened to posts with half-inch staples or 16-gauge wire ties spaced a maximum of 6 inches.
3. A 12-inch trench will be excavated along the uphill side of the silt fence posts. The bottom edge of the fabric will extend across the bottom of the trench. The trench will be backfilled to 4 inches above ground and compacted to bury and secure the bottom of the filter fabric.

Fiber Rolls

BMP Description: Fiber rolls will be installed in the vegetated swale (see Section 2, Part 2.6) and around the perimeter of the individual housing lots where individual lot grading and housing construction is beginning, see Inset 1 Site Map. The rolls will consist of rolled tubes of erosion control blankets (8 inches in diameter) and bound at each end with jute-type twine. The rolls will be installed in shallow trenches dug 2–4 inches below ground surface and staked into the ground using wooden stakes (24 inches long) 3 to 4 feet apart. For design specifications, see Figure 7.

Installation Schedule:	The perimeter fiber rolls will be installed before grading and construction begins on the individual housing lot.
Maintenance and Inspection:	The fiber rolls will be inspected weekly and immediately after storm events for split, torn, unraveled or slumping rolls. Any split, torn, unraveled or slumping rolls found during the inspection will be repaired or replaced immediately. Accumulated sediment will be removed when accumulation reaches one-third the height of the fiber roll and hauled off-site for disposal at Springfield Landfill. If accumulated sediment is creating noticeable strain on the rolls and the rolls might fail from a sudden storm event, the sediment will be removed more frequently. Before the fiber rolls are removed from the project area, the sediment will be removed. The anticipated life span of the fiber rolls is 6 months and will likely need to be replaced after this time span.
Responsible Staff:	RBI Development will be responsible for implementing perimeter controls on lots A2–A16. <i>LOTS C1-C10 - COASTAL CREEK BUILDING</i>

Figure 7. Fiber rolls

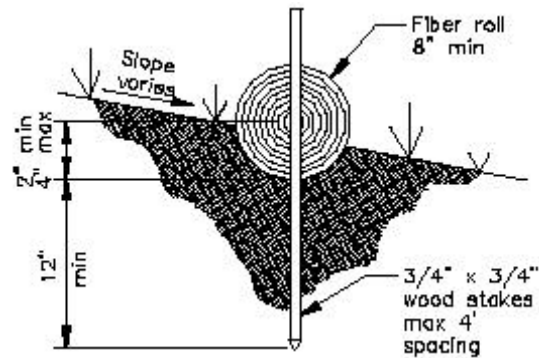

Design Specifications

1. Fiber rolls will be either prefabricated rolls or rolled tubes of an erosion control blanket.
2. Field rolled fiber roll is assembled by rolling the length of erosion control blanket into a tube of minimum 8-inch diameter and binding the roll at each end and every 4 feet along the length of the roll with jute-type twine.
3. Use wood stakes with a nominal classification of 0.75 x 0.75 inch and minimum length of 24 inches.
4. Stake fiber rolls into a 2- to 4-inch-deep trench with a width equal to the diameter of the fiber roll. Drive stakes at the end of each fiber roll and spaced 4 feet maximum on center.

2.8 Retain Sediment On-Site

Instructions:

- Describe sediment control practices (e.g., sediment trap or sediment basin), including design specifications and details (volume, dimensions, outlet structure) that will be implemented at the construction site to retain sediments on-site. (For more information, see *SWPPP Guide*, Chapter 4, ESC Principle 8 or EPA’s CGP Part 3.13.E.)
- Also, see EPA’s *Sediment Basin BMP Fact Sheet* at www.epa.gov/npdes/stormwater/menuofbmps/construction/sediment_basins

Sediment Basin

BMP Description: An access road will be installed on lot A1 for the basin. The road will be cleared and grubbed, graded, and stabilized with crushed stone 2–4 inches in diameter and have a minimum width of 10 feet. The sediment basin will be constructed in the northeast corner of the construction site to remove sediment from stormwater runoff. The basin will be constructed to have a total volume of 80,000 cubic feet. The design volume is based on calculations required in Twin Falls County’s stormwater ordinance (Ch. 10.3):

$$\text{Design Volume} = 3,600 \text{ cubic feet} \times \text{Area}$$

$$\text{Design Volume} = (3,600 \text{ cu ft/acre}) \times 20 \text{ acres} = 72,000 \text{ cubic feet}$$

The 80,000 cubic feet volume is slightly larger than the required volume. This is also larger than EPA’s minimum required volume of a sediment basin of 3,600 cubic feet of storage per acre of drained (or 72,000 cubic feet).

The basin will drain—through a riser pipe open at the top with a trash rack and outlet pipe with anti-seep collars—to a riprap spillway leading to a level spreader, which will discharge to a natural vegetated area before discharging into Utah Creek. The slopes of the basin will be stabilized using erosion controls as described in Section 2, Part 2.4. A silt fence will surround the basin on the upper slopes to protect against erosion of the embankments. Influent to the basin will be supplied by a stormwater pipe on the south end of the basin and drainage from the earth dike channel. For design specifications, see Figure 8. The sediment basin will be converted to a permanent detention basin following completion of construction activities at the site, see Section 4. After the conversion, a chain link fence will be installed around the perimeter and signs will be posted on the fence indicating “danger.”

Installation Schedule:

The access road and basin will be installed before site grading begins at the site.

<p>Maintenance and Inspection:</p>	<p>The basin will be inspected weekly and immediately after storm events. The banks of the basin will be checked for erosion, seepage, and structural damage. Any damage to the embankments will be repaired immediately. The inlets, outlets, and spillway will be checked for any damage or obstructions and any damage present will be repaired and the obstruction removed. Accumulated sediments will be removed when one-half of the volume of sediment capacity storage is reached. The removed sediments will be hauled off-site for disposal at Springfield Landfill.</p>
<p>Responsible Staff:</p>	<p>RBI Development</p>

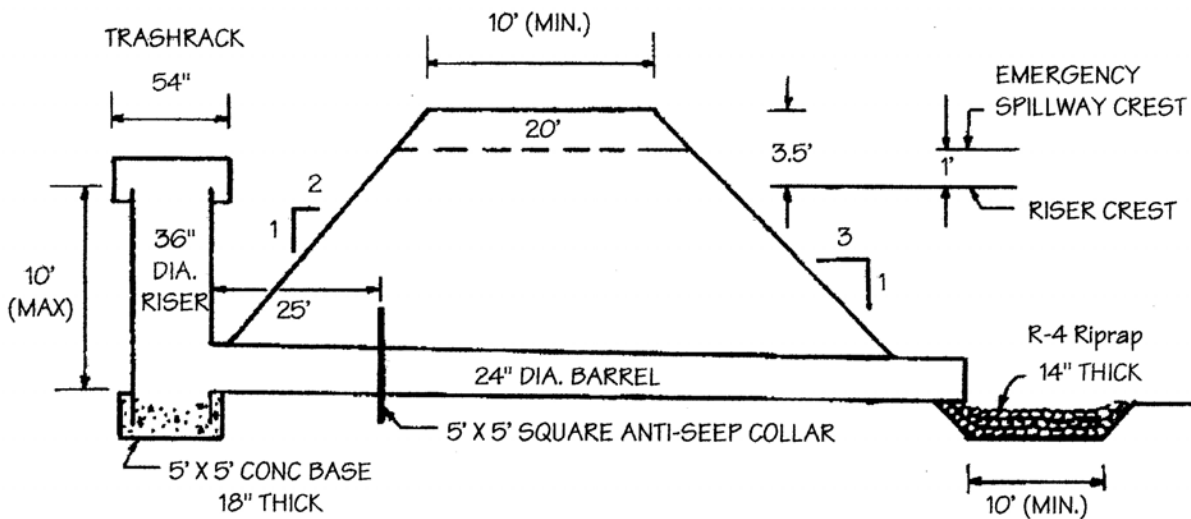

Figure 8. Sediment basin

Design Specifications

1. The area will be cleared, grubbed and stripped of any vegetation and root mat. The pool area will be cleared.
2. The fill material for the embankment will be free of any vegetation, root mat, rocks, or oversized stones. The embankment will be compacted by traversing with equipment.
3. Slopes will be stabilized in accordance with Section 2, Part 2.4.

2.9 Establish Stabilized Construction Exits

Instructions:

- Describe location(s) of vehicle entrance(s) and exit(s), procedures to remove accumulated sediment off-site (e.g., vehicle tracking), and stabilization practices (e.g., stone pads or wash racks or both) to minimize off-site vehicle tracking of sediments and discharges to stormwater. (For more information, see *SWPPP Guide*, Chapter 4, ESC Principle 9 and EPA’s CGP Part 3, Subparts 3.4.G and 3.13.B.)
- Also, see EPA’s *Construction Entrances BMP Fact Sheet* at www.epa.gov/npdes/stormwater/menuofbmps/construction/cons_entrance

Stabilized Construction Exits before Roads are Paved

BMP Description: Stone anti-tracking pads will be installed at each exit, as identified on the site map, to prevent the off-site transport of sediment by construction vehicles. The stabilized exits will be a least 50 feet long, a minimum of 10 feet wide, flared at the end closest to the paved road, and will consist of a 6–inch-thick layer of crushed stone (2 inches in diameter). The crushed stone will be placed over a layer of geotextile filter fabric to reduce the mitigation of sediment from the underlying soil. Orange-colored plastic mesh fence will be installed along the length of the construction exit to keep construction vehicles and equipment on the stone anti-tracking pads. For design specifications, see Figure 9.

Installation Schedule:	The stabilized exit will be installed before construction begins on the site. The stone anti-tracking pads will remain in place until the subgrade of pavement is installed at the site.
Maintenance and Inspection:	The stabilized exit will be inspected weekly and after storm events or heavy use. The exit to the construction site will be maintained in a condition that will prevent sediment tracking off-site. This could require adding additional crushed stone to the exit. All sediment tracked, spilled, dropped, or washed onto the road will be swept up immediately and hauled off-site for disposal at Springfield Landfill. Once sediment clogs the voids in the crushed stone and the effectiveness of the anti-tracking pad is no longer keeping sediment on the site, the pad will be toppedressed with new crushed stone. Replacement of the entire pad might be necessary when the pad becomes completely filled with sediment. The pad will be reshaped as needed for drainage and runoff control. Broken road pavement as a result of construction activities on roadways immediately adjacent to the project site will be repaired immediately. The stone anti-tracking pad will be removed before the subgrade of pavement is applied to Johnson Loop. The removed stone and sediment from the pad will be hauled off-site and disposed of at Springfield Landfill.
Responsible Staff:	RBI Development

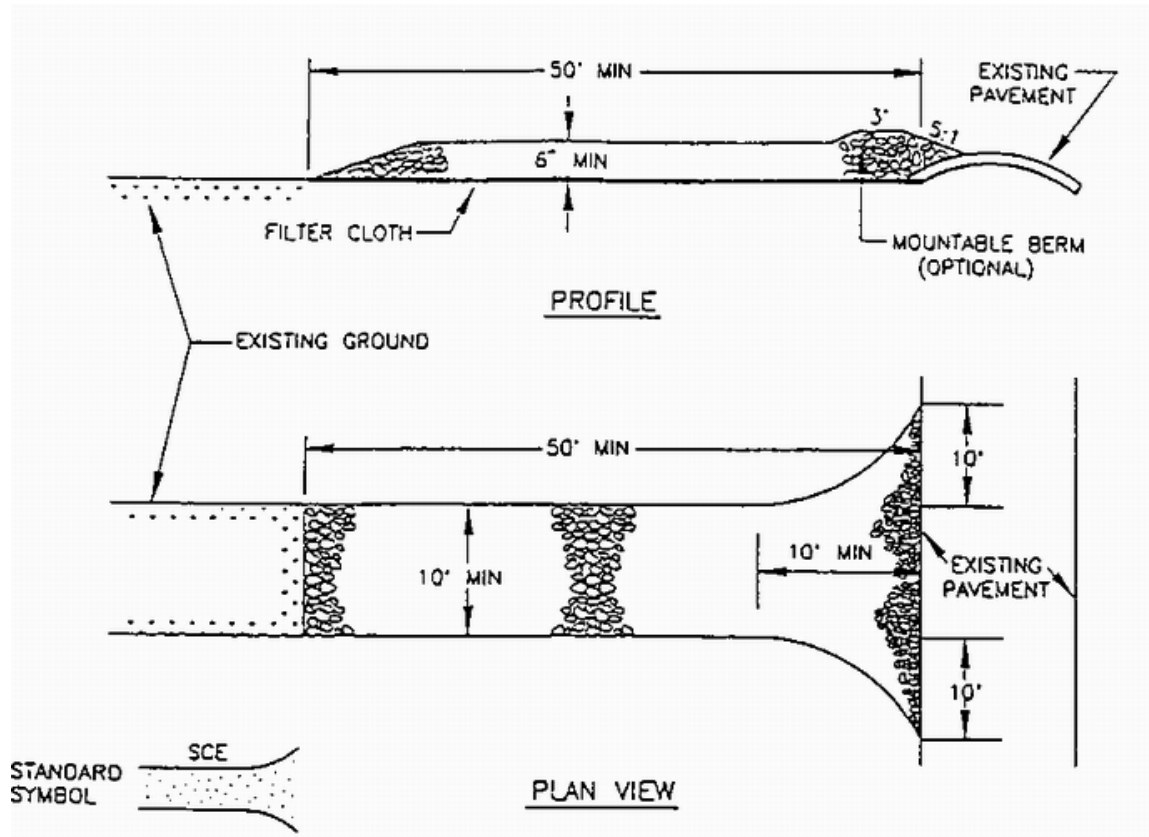

Figure 9. Stabilized construction exit

Design Specifications

1. Stone applied to the pad will be 2-inch stone.
2. The length of the pad will not be less than 50 feet (except on a single residence lot where a 30-foot minimum would apply).
3. The thickness of the pad will not be less than 6 inches.
4. The width of pad will be a minimum of 10 feet.
5. Filter fabric will be placed over the entire area before placing the stone. Fabric will not be required for individual lot exits.

Stabilized Exits for Individual Lots

BMP Description: Stone anti-tracking pads will be installed at each housing lot to prevent the off-site transport of sediment by construction vehicles. The stabilized exits will have a minimum length of 30 feet, per Twin Falls County’s stormwater ordinance (CH. 20.1) and will consist of a 6-inch thick layer of crushed stone (2 inches in diameter). For design specifications, see Figure 10.

Installation Schedule:	The stabilized exit will be installed before construction begins on the individual housing lots once the main access road has been paved.
Maintenance and Inspection:	The stabilized exit will be inspected weekly and after storm events or heavy use. The exit to the housing lot will be maintained in a condition that will prevent sediment tracking onto Johnson Loop. This might require adding additional crushed stone to the exit. All sediment tracked, spilled, dropped, or washed onto Johnson Loop will be swept up immediately and hauled off-site for disposal at Springfield Landfill. Once sediment clogs the voids in the crushed stone and the effectiveness of the anti-tracking pad is no longer keeping sediment on-site, the pad will be toppedressed with new crushed stone. Replacement of the entire pad might be necessary when the pad becomes completely filled with sediment. The pad will be reshaped as needed for drainage and runoff control.
Responsible Staff:	RBI Development / COASTAL CREEK BUILDING

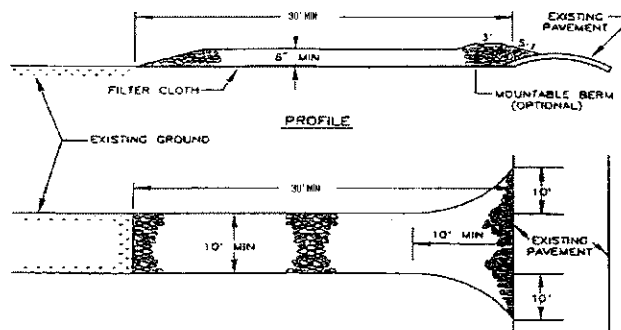

Figure 10. Stabilized construction exit (individual lot)

Design Specifications

1. Stone applied to the pad will be 2-inch stone.
2. The length of the pad will be a minimum of 30 feet.
3. The thickness of the pad will not be less than 6 inches.
4. The width of pad will be a minimum of 10 feet.

Stabilized Construction Exits after Roads are Paved

BMP Description: After roads have been paved, a metal “rumble pad” will be placed at each construction exit for Johnson Loop to shake sediment from vehicle tires. The rumble pad will have a minimum length of 24 feet.

Installation Schedule:	The rumble pads will be installed at the exits immediately after paving operations are complete.
Maintenance and Inspection:	Inspect rumble pads weekly and after storm events for signs of damage or excess sediment. Remove excess sediment from the rumble pad by sweeping.
Responsible Staff:	RBI Development

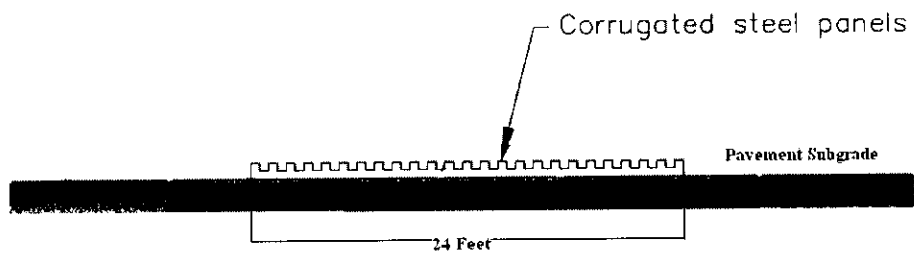

NOT TO SCALE

Figure 12. Rumble Pad

2.10 Additional BMPs

Instructions:

- Describe additional BMPs that do not fit into the above categories.

Street Sweeping

BMP Description: Super Sweeping will perform street sweeping and vacuuming on the main road of the subdivision (Johnson Loop) and Williams Avenue. Super Sweeping will use a regenerative air sweeper to remove sediments and other contaminants directly from the paved surfaces.

Installation Schedule:	Street sweeping will occur weekly and before forecasted storm events on Williams Avenue and Johnson Loop
Maintenance and Inspection:	All materials collected during street sweeping will be disposed of at an off-site location by the subcontractor.
Responsible Staff:	RBI Development

Cooperative Agreement and Operator Communication

BMP Description: All construction operators working on the Clover Hills Subdivision project are required to sign the Construction Operator’s Cooperative Agreement (See Part 1.2) and agree to abide by the conditions of the agreement throughout the duration of the construction project regardless of whether the operator agrees to be covered under this SWPPP.

RBI Development will hold biweekly meetings to update operators on CGP compliance issues and to discuss any issues related to implementation of this SWPPP. RBI will maintain the SWPPP documentation and will conduct and document self-inspections in all areas of the site under its day-to-day control. RBI will provide copies of inspection reports to the other operators covered by this SWPPP immediately following each inspection.

Responsible Staff:	RBI Development / COASTAL CREEK BUILDING / FALLS HOMES
---------------------------	--------------------------------------------------------

SECTION 3: GOOD HOUSEKEEPING BMPS

Instructions:

- Describe the key good housekeeping and pollution prevention (P2) measures that will be implemented to control pollutants in stormwater.
- Categorize each good housekeeping and pollution prevention (P2) BMP under one of the following seven categories:
 - 3.1 *Material Handling and Waste Management*
 - 3.2 *Establish Proper Building Material Staging Areas*
 - 3.3 *Designate Washout Areas*
 - 3.4 *Establish Proper Equipment/Vehicle Fueling and Maintenance Practices*
 - 3.5 *Allowable Non-Stormwater Discharges and Control Equipment/Vehicle Washing*
 - 3.6 *Spill Prevention and Control Plan*
 - 3.7 *Any Additional BMPS*
- For more information, see *SWPPP Guide*, Chapter 5 and EPA's CGP Part 3, Subparts 3.4.(F), (G), (H), and (I).
- Consult your state's design manual or resources in Appendix D of the *SWPPP Guide*.
- For more information or ideas on BMPS, see EPA's National Menu of BMPS
<http://www.epa.gov/npdes/stormwater/menuofbmps>

3.1 *Material Handling and Waste Management*

Instructions:

- Describe measures (e.g., trash disposal, sanitary wastes, recycling, and proper material handling) to prevent the discharge of solid materials to waters, except as authorized by a permit issued under section 404 of the CWA (For more information, see *SWPPP Guide*, Chapter 5, P2 Principle 1.)
- Also, see EPA's *General Construction Site Waste Management BMP Fact Sheet* at www.epa.gov/npdes/stormwater/menuofbmps/construction/cons_wasteman

Waste Materials

BMP Description: All waste materials will be collected and disposed of into two metal trash dumpsters in the combined staging area. Dumpsters will have a secure watertight lid, be placed away from stormwater conveyances and drains, and meet all local and state solid-waste management regulations. Only trash and construction debris from the site will be deposited in the dumpsters. All personnel will be instructed, during tailgate training sessions, regarding the correct procedure for disposal of trash and construction debris. Notices that state these practices will be posted in the office trailer and the individual who manages day-to-day site operations will be responsible for seeing that these practices are followed.

Installation Schedule:

Trash dumpsters will be installed once the combined staging area has been established.

Maintenance and Inspection:	The dumpsters will be inspected weekly and immediately after storm events. The dumpster will be emptied weekly and taken to Springfield Landfill by Drake Waste and Sanitary Services. If trash and construction debris are exceeding the dumpsters capacity, the dumpsters will be emptied more frequently.
Responsible Staff:	RBI Development / <i>COASTAL CREEK BUILDING</i>

Hazardous Waste

BMP Description: All hazardous waste materials such as oil filters, petroleum products, paint, and equipment maintenance fluids will be stored in structurally sound and sealed shipping containers in the hazardous-materials storage area and segregated from other non-waste materials. Secondary containment will be provided for all materials in the hazardous materials storage area and will consist of commercially available spill pallets. Additionally, all hazardous materials will be disposed of in accordance with federal, state, and municipal regulations. Hazardous waste materials will not be disposed of into the on-site dumpsters. All personnel will be instructed, during tailgate training sessions, regarding proper procedures for hazardous waste disposal. Notices that state these procedures will be posted in the office trailer and the individual who manages day-to-day site operations will be responsible for seeing that these procedures are followed.

Installation Schedule:	Shipping containers used to store hazardous waste materials will be installed once the materials storage area has been installed for the site and individual lots.
Maintenance and Inspection:	The hazardous materials storage areas will be inspected weekly and after storm events. The storage areas will be kept clean, well organized, and equipped with ample cleanup supplies as appropriate for the materials being stored. Material safety data sheets, material inventory, and emergency contact numbers will be maintained in the office trailer.
Responsible Staff:	RBI Development / <i>COASTAL CREEK BUILDING</i>

Sanitary Waste

BMP Description: Two temporary sanitary facilities (portable toilets) will be provided at the site in the combined staging area. The toilets will be away from a concentrated flow paths and traffic flow and will have collection pans underneath as secondary containment.

Installation Schedule:	The portable toilets will be brought to the site once the combined staging area has been established.
Maintenance and Inspection:	All sanitary waste will be collected from the portable toilets a minimum of three times per week by Drake Waste and Sanitary Services. The toilets will be inspected weekly for evidence of leaking holding tanks. Toilets with leaking holding tanks will be removed from the site and replaced with new portable toilets.
Responsible Staff:	RBI Development / <i>COASTAL CREEK BUILDING</i>

Recycling

BMP Description: Wood pallets, cardboard boxes, and other recyclable construction scraps will be disposed of in a designated dumpster for recycling. The dumpster will have a secure watertight lid, be placed away from stormwater conveyances and drains and meet all local and state solid-waste management regulations. Only solid recyclable construction scraps from the site will be deposited in the dumpster. All personnel will be instructed, during tailgate training sessions, regarding the correct procedure for disposal of recyclable construction scraps. Notices that state these procedures will be posted in the office trailer, and the individual who manages day-to-day site operations will be responsible for seeing that these procedures are followed.

Installation Schedule:	The designated recycling dumpster will be installed once the combined staging area has been established.
Maintenance and Inspection:	The recycling dumpster will be inspected weekly and immediately after storm events. The recycling dumpster will be emptied weekly and taken to an approved recycling center by Drake Waste and Sanitary Services. If recyclable scraps (wood pallets, cardboard boxes, and other recyclable construction scraps) are exceeding the dumpster's capacity, the dumpster will be emptied more frequently.
Responsible Staff:	RBI Development / COASTAL CREEK BUILDING

3.2 Establish Proper Building Material Staging Areas

Instructions:

- Describe construction materials expected to be stored on-site and procedures for storage of materials to minimize exposure of the materials to stormwater. (For more information, see *SWPPP Guide*, Chapter 5, P2 Principle 2 and EPA's CGP Part 3.4.H.)

Combined Staging Area

BMP Description: Construction equipment and maintenance materials will be stored at the combined staging area and materials storage areas. Gravel bag berms will be installed around the perimeter to designate the staging and materials storage area. A watertight shipping container will be used to store hand tools, small parts, and other construction materials.

Nonhazardous building materials such as packaging material (wood, plastic, and glass), and construction scrap material (brick, wood, steel, metal scraps, and pipe cuttings) will be stored in a separate covered storage facility adjacent to the shipping container. All hazardous-waste materials such as oil filters, petroleum products, paint, and equipment maintenance fluids will be stored in structurally sound and sealed containers under cover within the hazardous materials storage area.

Large items, such as framing materials and stockpiled lumber, will be stored in the open in the storage area. Such materials will be elevated on wood blocks to minimize contact with runoff.

Installation Schedule:	The combined staging and materials storage area will be installed after grading and before any infrastructure is constructed at the site. The material storage areas for individual lots will be installed before construction begins for each house.
Maintenance and Inspection:	Storage areas will be inspected weekly and after storm events. Storage areas will be kept clean, well organized, and equipped with ample cleanup supplies as appropriate for the materials being stored. Perimeter controls, containment structures, covers, and liners will be repaired or replaced as needed to maintain proper function.
Responsible Staff:	RBI Development will be responsible for the overall combined staging area and materials storage area and individual materials storage areas on lots A2–A16.

LOTS C1-C10 - COASTAL CREEK BUILDING

3.3 Designate Washout Areas

Instructions:

- Describe location(s) and controls to eliminate the potential for discharges from washout areas for concrete mixers, paint, stucco, and so on. (For more information, see *SWPPP Guide*, Chapter 5, P2 Principle 3.)
- Also, see EPA's *Concrete Washout BMP Fact Sheet* at www.epa.gov/npdes/stormwater/menuofbmps/construction/concrete_wash

Concrete Washout

BMP Description: Designated temporary, below-ground concrete washout areas will be constructed on lots A4 and between lots C3–C4, as detailed on the site map. The temporary below ground will be constructed as shown in Figure 11, with a recommended minimum length and width of 10 feet, but with sufficient quantity and volume to contain all liquid and concrete waste generated by the washout operations. The washout areas will be lined with plastic sheeting at least 10 mils thick and free of any holes or tears. Signs will be posted marking the location of the washout area to ensure that concrete equipment operators use the proper facility.

Concrete pours will not be conducted during or before an anticipated storm event. All excess concrete and concrete washout slurries from the concrete mixer trucks and chutes will be discharged to the washout area or hauled off-site for disposal. When the temporary washout areas are no longer needed for the construction project, the hardened concrete and materials used to construct the areas will be removed and disposed of according to the maintenance section below and the washout areas will be backfilled, graded and stabilized with erosion controls. For design specifications, see Figure 11.

<i>Installation Schedule:</i>	The washout areas will be constructed before the active building phase of individual housing units.
<i>Maintenance and Inspection:</i>	The washout areas will be inspected daily to ensure that all concrete washing is being discharged into the washout area, no leaks or tears are present, and to identify when concrete wastes need to be removed. The washout areas will be cleaned out once the area is filled to 75 percent of the holding capacity. Once the area's holding capacity has been reached the concrete wastes will be allowed to harden, the concrete will be broken up, removed, and taken to Springfield Landfill for disposal. The plastic sheeting will be replaced if tears occur during removal of concrete wastes from the washout area.
<i>Responsible Staff:</i>	RBI Development

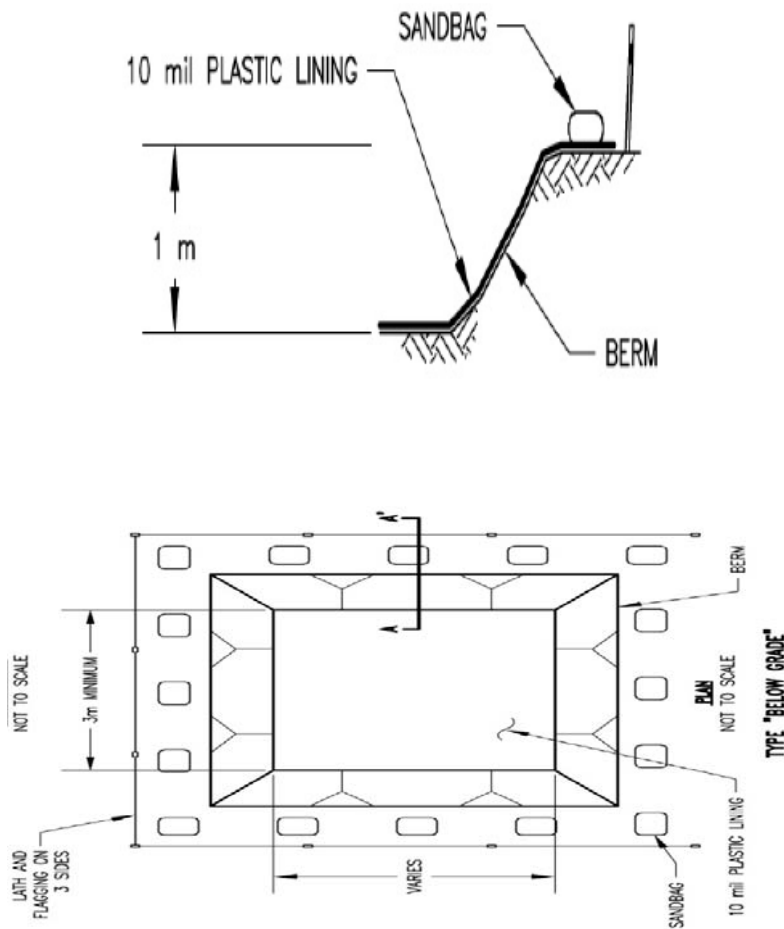

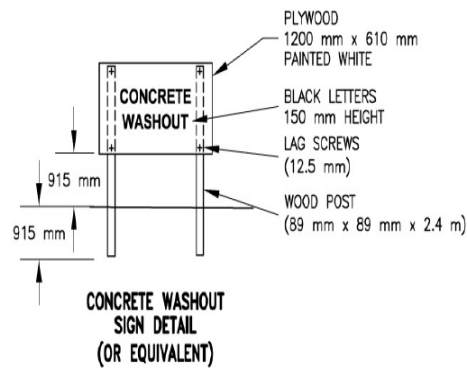

Figure 11. Temporary concrete washout

Design Specifications

1. Temporary concrete washout facility type *Below Grade* will be constructed as shown above, with a recommended minimum length and minimum width of 10 feet.
2. Temporary concrete washout facilities will be located a minimum of (50 feet) from storm drain inlets.
3. Plastic lining material will be free of holes, tears or other defects that compromise the impermeability of the material.

3.4 Establish Proper Equipment/Vehicle Fueling and Maintenance Practices

Instructions:

- Describe equipment/vehicle fueling and maintenance practices that will be implemented to control pollutants to stormwater (e.g., secondary containment, drip pans, and spill kits) (For more information, see *SWPPP Guide*, Chapter 5, P2 Principle 4.)
- Also, see EPA's *Vehicle Maintenance and Washing Areas BMP Fact Sheet* at www.epa.gov/npdes/stormwater/menuofbmps/construction/vehicile_maintain

Vehicle/Equipment Fueling and Maintenance

BMP Description: Several types of vehicles and equipment will be used on-site throughout the project, including graders, scrapers, excavators, loaders, paving equipment, rollers, trucks and trailers, backhoes, and forklifts. All major equipment/vehicle fueling and maintenance will be performed off-site. A small, 20-gallon pickup bed fuel tank will be kept on-site in the combined staging area. When vehicle fueling must occur on-site, the fueling activity will occur in the staging area. Only minor equipment maintenance will occur on-site. All equipment fluids generated from maintenance activities will be disposed of into designated drums stored on spill pallets in accordance with Section 3, Part 3.1. Absorbent, spill-cleanup materials and spill kits will be available at the combined staging and materials storage area. Drip pans will be placed under all equipment receiving maintenance and vehicles and equipment parked overnight.

Installation Schedule:	Equipment and vehicle maintenance and fueling practices will be implemented at the beginning of construction on-site.
Maintenance and Inspection:	Inspect equipment/vehicle storage areas and fuel tank weekly and after storm events. Vehicles and equipment will be inspected on each day of use. Leaks will be repaired immediately, or the problem vehicle(s) or equipment will be removed from the project site. Keep ample supply of spill-cleanup materials on-site and immediately clean up spills and dispose of materials properly.
Responsible Staff:	RBI Development

3.5 Control Equipment/Vehicle Washing

<p>Instructions:</p> <ul style="list-style-type: none"> – Describe equipment/vehicle washing practices that will be implemented to control pollutants to stormwater. (For more information, see <i>SWPPP Guide</i>, Chapter 5, P2 Principle 5.) – Also, see EPA's <i>Vehicle Maintenance and Washing Areas BMP Fact Sheet</i> at www.epa.gov/npdes/stormwater/menuofbmps/construction/vehicile_maintain

BMP Description: All equipment and vehicle washing will be performed off-site.

Installation Schedule:	N/A
Maintenance and Inspection:	N/A
Responsible Staff:	RBI Development

3.6 Spill Prevention and Control

<p>Instructions:</p> <ul style="list-style-type: none"> – Describe the spill prevention and control procedures to include ways to reduce the chance of spills, stop the source of spills, contain and clean up spills, dispose of materials contaminated by spills, and train personnel responsible for spill prevention and control. (For more information, see <i>SWPPP Guide</i>, Chapter 5, P2 Principle 6 and EPA's CGP Parts 4.3 and 4.4.) – Also, see EPA's <i>Spill Prevention and Control Plan BMP Fact sheet</i> at www.epa.gov/npdes/stormwater/menuofbmps/construction/spill_control

Spill Prevention and Control Procedures

BMP Description:

- i. Employee Training: All employees will be trained via biweekly tailgate sessions, as detailed in Section 6, Part 6.3.
- ii. Vehicle Maintenance: Vehicles and equipment will be maintained off-site. All vehicles and equipment including subcontractor vehicles will be checked for leaking

- oil and fluids. Vehicles leaking fluids will not be allowed on-site. Drip pans will be placed under all vehicles and equipment that are parked overnight.
- iii. **Hazardous Material Storage:** Hazardous materials will be stored in accordance with Section 3, Part 1 and federal and municipal regulations.
 - iv. **Spill Kits:** Spill kits will be within the materials storage area and concrete washout areas.
 - v. **Spills:** All spills will be cleaned up immediately upon discovery. Spent absorbent materials and rags will be hauled off-site immediately after the spill is cleaned up for disposal at Springfield Landfill. Spills large enough to discharge to surface water will be reported to the National Response Center at 1-800-424-8802.
 - vi. **Material safety data sheets, a material inventory, and emergency contact information** will be maintained at the on-site project trailer.

Installation Schedule:	The spill prevention and control procedures will be implemented once construction begins on-site.
Maintenance and Inspection:	All personnel will be instructed, during tailgate training sessions, regarding the correct procedures for spill prevention and control. Notices that state these practices will be posted in the office trailer, and the individual who manages day-to-day site operations will be responsible for seeing that these procedures are followed.
Responsible Staff:	RBI Development / COASTAL CREEK BUILDING

3.7 Any Additional BMPs

Instructions:

- Describe any additional BMPs that do not fit into the above categories. Indicate the problem they are intended to address.

BMP Description: No Additional BMPs were identified.

Installation Schedule:	N/A
Maintenance and Inspection:	N/A
Responsible Staff:	RBI Development

3.8 Allowable Non-Stormwater Discharge Management

Instructions:

- Identify all allowable sources of non-stormwater discharges that are not identified. The allowable non-stormwater discharges identified in Part 1.3.B of EPA’s CGP include
 - ✓ Discharges from fire-fighting activities
 - ✓ Fire hydrant flushings
 - ✓ Waters used to wash vehicles where detergents are not used
 - ✓ Water used to control dust in accordance with EPA’s CGP, Part 3, Subpart 3.4.G
 - ✓ Potable water including uncontaminated water line flushings
 - ✓ Routine external building wash down that does not use detergents
 - ✓ Pavement wash waters where spills or leaks of toxic or hazardous materials have not occurred (unless all spilled material has been removed) and where detergents are not used
 - ✓ Uncontaminated air conditioning or compressor condensate
 - ✓ Uncontaminated ground water or spring water
 - ✓ Foundation or footing drains where flows are not contaminated with process materials such as solvents
 - ✓ Uncontaminated excavation dewatering
 - ✓ Landscape irrigation
- Identify measures used to eliminate or reduce these discharges and the BMPs used to prevent them from becoming contaminated.
- For more information, see *SWPPP Guide*, Chapter 3.A or EPA’s CGP Part 1.3.B and 3.5.

List allowable non-stormwater discharges and the measures used to eliminate or reduce them and to prevent them from becoming contaminated:

Any changes in construction activities that produce other allowable non-stormwater discharges will be identified, and the SWPPP will be amended and the appropriate erosion and sediment control will be implemented.

Water Used to Control Dust

BMP Description: Dust control will be implemented as needed once site grading has been initiated and during windy conditions (forecasted or actual wind conditions of 20 mph or greater) while site grading is occurring. Spraying of potable water at a rate of 300 gallons per acre or less will be performed by a mobile pressure-type distributor truck no more than three times a day during the months of May–September and once per day during the months of October–April or whenever the dryness of the soil warrants it.

Responsible Staff:	RBI Development
---------------------------	-----------------

Uncontaminated Excavation Dewatering

BMP Description: Because construction for this site is being conducted during the dry season, dewatering activities are not expected to occur at the project site. If dewatering does occur, the SWPPP will be revised to address the need for appropriate BMPs.

Responsible Staff:	RBI Development
---------------------------	-----------------

Landscape Irrigation

BMP Description: Irrigation waters will not be sprayed onto impermeable surfaces such as paved driveways and roads. Waters will be directed onto soil and lawns by using hoses and correctly sized sprinklers with adjustable spray patterns. To avoid discharges of irrigation waters, the sprinklers will have low-flow rates and increased watering time. The irrigated area will be inspected for excess watering and to adjust watering times and schedules.

Responsible Staff:	RBI Development
---------------------------	-----------------

Uncontaminated Water Line Flushing

BMP Description: Uncontaminated water from water line flushing of the site infrastructure will be discharged to the sediment basin, while avoiding any contact with disturbed areas. If water from the line flushing becomes contaminated, the water line will be blocked off and the flush water will be pumped to a tanker truck, which will haul the contaminated water off-site to Middletown POTW for disposal.

Responsible Staff:	RBI Development
---------------------------	-----------------

SECTION 4: SELECTING POST-CONSTRUCTION BMPs

Instructions:

- Describe all post-construction stormwater management measures that will be installed during the construction process to control pollutants in stormwater discharges after construction operations have been completed. Examples of post-construction BMPs include the following:
 - ✓ Biofilters
 - ✓ Detention/retention devices
 - ✓ Earth dikes, drainage swales, and lined ditches
 - ✓ Infiltration basins
 - ✓ Porous pavement
 - ✓ Other proprietary permanent structural BMPs
 - ✓ Outlet protection/velocity dissipation devices
 - ✓ Slope protection
 - ✓ Vegetated strips and/or swales
- Identify any applicable federal, state, local, or tribal requirements for design or installation.
- Describe how low-impact designs or smart growth considerations have been incorporated into the design.
- For any structural BMPs, you should have design specifications and details and refer to them. Attach them as appendices to the SWPPP or within the text of the SWPPP.
- For more information on this topic, see your state’s stormwater manual.
- You might also want to consult one of the references listed in Appendix D of the *SWPPP Guide* and EPA’s CGP Part 3, Subparts 3.4.E and 3.9.
- Visit the post-construction section of EPA’s Menu of BMPs at: www.epa.gov/npes/menuofbmps

Detention Basin

BMP Description: To convert the sediment basin to a detention basin, RBI Development will excavate the bottom of the basin to remove accumulated sediments and increase the storage capacity of the basin below the lowest orifice in the basin’s outlet to retain stormwater temporarily. An earthen berm will be constructed from the excavated earth and configured to extend across the flow path of the basin to separate the sediment forebay and the main pool of the basin. The sediment forebay will be installed within the basin near the inlet to capture sediment, debris and provide pretreatment of stormwater runoff before releasing the runoff into the main pool of the basin. The outlet structure design does not need to be modified for this conversion process. The detention basin will be stabilized with erosion controls as detailed in Section 7. Design specifications are omitted from this example SWPPP.

<i>Installation Schedule:</i>	The basin will be converted to a permanent detention basin during the final stabilization phase of construction.
<i>Maintenance and Inspection:</i>	The basin area will be inspected weekly and after storm events during the conversion process. The area will be checked for signs of erosion, seepage, and structural damage. Erosion, seepage, and structural damage will be repaired immediately. The outlet and trash rack will be checked for any damage or obstructions and any

	damage found will be repaired and obstructions removed. Immediately after the completion of construction, the plant material will be watered for 14 consecutive days unless there is sufficient natural rainfall. The area will be monitored until final stabilization is reached.
Responsible Staff:	RBI Development

Vegetated Swale

BMP Description: The vegetated swale as described in Section 2, Part 2.3 will remain as a permanent stormwater management structure for the site. The swale will convey runoff to an inlet south of lot A12.

Installation Schedule:	The swale will be installed according to the schedule found in Section 2, Part 2.3.
Maintenance and Inspection:	See Section 2, Part 2.3 for maintenance and inspection procedures for the vegetated swale. The area will be monitored until final stabilization is reached.
Responsible Staff:	RBI Development

Earth Dike

BMP Description: The earth dike as described in Section 2, Part 2.3 will remain as a permanent stormwater management structure for the site. The earth dike will convey runoff to the detention basin.

Installation Schedule:	The earth dike will be installed according to the schedule found in Section 2, Part 2.3.
Maintenance and Inspection:	See Section 2, Part 2.3 for maintenance and inspection procedures for the earth dike. The area will be monitored until final stabilization is reached.
Responsible Staff:	RBI Development

Storm Drain Inlet Markers

BMP Description: The storm drain inlets on the site will be stamped with warning signs informing the public not to dump pollutants into the drain. The markers will be approximately 6 inches round and will be attached to the inlet using a manufacturer approved adhesive.

Installation Schedule:	Storm drain markers will be installed once final pavement of Johnson Loop has been completed.
Maintenance and Inspection:	N/A
Responsible Staff:	RBI Development

SECTION 5: INSPECTIONS

5.1 Inspections

Instructions:

- Identify the individual(s) responsible for conducting inspections and describe their qualifications. Reference or attach the inspection form that will be used.
- Describe the frequency that inspections will occur at your site including any correlations to storm frequency and intensity.
- Note that inspection details for particular BMPs should be included in Sections 2 and 3.
- You should also document the repairs and maintenance that you undertake as a result of your inspections. These actions can be documented in the corrective action log described in Part 5.3 below.
- For more on this topic, see *SWPPP Guide*, Chapters 6 and 8 and EPA's CGP Part 3, Subparts 3.6.A, 3.10 and 3.11.C.
- Also, see suggested inspection form in Appendix B of the *SWPPP Guide*.

1. *Inspection Personnel:* Identify the person(s) who will be responsible for conducting inspections and describe their qualifications:

- Ms. Dorothy Williams, CGP Compliance/Inspection Officer, is responsible for site compliance with this SWPPP and EPA's Construction General Permit. Ms. Williams will conduct inspections for all areas of the site disturbed by construction activity, areas used for storage of materials that are exposed to precipitation, discharge points, and construction exits. *LOTS B1-B9 OWNED BY FALLS HOMES - NOT INCLUDED IN SITE INSPECTIONS*

In the absence of Ms. Williams, Mark Wilson, Associate Compliance Officer for RBI Development, will conduct inspections.

- *Qualifications:*

Dorothy Williams

1. Ms. Williams has developed construction SWPPPs for more than 30 different construction projects and conducted inspections for those construction projects.
2. She has more than 20 years of experience complying with stormwater regulations.
3. She received certification as a Certified Professional in Erosion and Sediment Control (CPESC) in August 2000 (see Appendix L).
4. She completed the *Fundamentals of Erosion Protection and Sediment Control* training workshop in Twin Falls County, July 2005 (see Appendix L).

Mark Wilson

1. Mr. Wilson has developed construction SWPPPs for 10 different construction projects and conducted inspections for those construction projects.

2. He received certification as a Certified Professional in Erosion and Sediment Control (CPESC) in June 2003.

2. Inspection Schedule and Procedures:

Describe the inspection schedules and procedures you have developed for your site (include frequency of inspections for each BMP or group of BMPs, indicate when you will inspect, e.g., before/during/and after rain events, spot inspections):

The CGP requires inspections (1) at least once every 7 days or (2) at least once every 14 days and within 24 hours of the end of a storm event of one-half inch or greater; however, because Ms. Dorothy Williams is on-site everyday, she will conduct inspections weekly and within 24 hours after each major storm event of one-half inch or greater. The inspections will verify that all BMPs required in Sections 2 and 3 are implemented, maintained, and effectively minimizing pollutants in stormwater runoff from the project site. For detailed inspection procedures for each BMP implemented at the site, see Sections 2 and 3.

Describe the general procedures for correcting problems when they are identified. Include responsible staff and time frames for making corrections.

- If corrective actions are identified by Ms. Williams during the inspection for areas under day-to-day control by RBI Development, she will notify and submit a copy of the inspection report to the Project Manager, Mr. Jared Strong. Mr. Strong will be responsible for initiating the corrective action within 24 hours of the report and completing maintenance as soon as possible or before the next storm event.
- If corrective actions are identified by Ms. Williams during the inspection for areas under control by Coastal Creek Building, she will notify and submit a copy of the inspection report to the project manager, Mr. Jared Strong and the project manager of Coastal Creek Building, Mr. Tony Groff. Mr. Groff will be responsible for initiating the corrective action within 24 hours of the report and completing maintenance as soon as possible or before the next storm event.

Attach a copy of the inspection report you will use for your site:

For a copy of the inspection report, see Appendix E.

5.2 Delegation of Authority

Instructions:

- Identify the individual(s) or specifically describe the position where the construction site operator has delegated authority for the purposes of signing inspection reports, certifications, or other information.
- Attach a copy of the signed delegation of authority form that will be used.
- For more on this topic, see *SWPPP Guide*, Chapter 7 and Appendix G, Subsection 11 of EPA's CGP.

Duly Authorized Representative(s) or Position(s):

RBI Development, LLC
Ms. Dorothy Williams
Compliance/Inspection Officer
13 South Avenue
Boise, ID 83701
(208) 555-5555
Dwilliams@rbi.com

See Appendix K – Delegation of Authority

5.3 Corrective Action Log

Instructions:

- Create here, or as an attachment, a corrective action log. This log should describe repair, replacement, and maintenance of BMPs undertaken as a result of the inspections and maintenance procedures described above. Actions related to the findings of inspections should reference the specific inspection report.
- This log should describe actions taken, date completed, and note the person that completed the work.

Corrective Action Log:

See Appendix F – Corrective Action Log

SECTION 6: RECORDKEEPING AND TRAINING

6.1 Recordkeeping

Instructions:

- The following is a list of records you should keep at your project site available for inspectors to review:
- Dates of grading, construction activity, and stabilization (which is covered in Sections 2 and 3)
- A copy of the construction general permit (attach)
- The signed and certified NOI form or permit application form (attach)
- A copy of the letter from EPA or the state notifying you of their receipt of your complete NOI/application (attach)
- Inspection reports (attach)
- Records relating to endangered species and historic preservation (attach)
- Check your permit for additional details
- For more on this subject, see *SWPPP Guide*, Chapter 6.C and EPA's CGP Part 3, Subparts 3.4.C, 3.8, 3.10.G and 3.12.A.

Records will be retained for a minimum period of at least 3 years after the permit is terminated.

Date(s) when major grading activities occur:

See Appendix I – Grading and Stabilization Activities Log

Date(s) when construction activities temporarily or permanently cease on a portion of the site:

See Appendix I – Grading and Stabilization Activities Log

Date(s) when an area is either temporarily or permanently stabilized:

See Appendix I – Grading and Stabilization Activities Log

6.2 Log of Changes to the SWPPP

Instructions:

- Create a log here, or as an attachment, of changes and updates to the SWPPP. You should include additions of new BMPs, replacement of failed BMPs, significant changes in the activities or their timing on the project, changes in personnel, changes in inspection and maintenance procedures, updates to site maps, and so on.

Log of changes and updates to the SWPPP

See Appendix G – SWPPP Amendment Log

6.3 Training

Instructions:

- Training your staff and subcontractors is an effective BMP. As with the other steps you take to prevent stormwater problems at your site, you should document the training that you conduct for your staff, for those with specific stormwater responsibilities (e.g. installing, inspecting, and maintaining BMPs), and for subcontractors.
- Include dates, number of attendees, subjects covered, and length of training.
- For more on this subject, see *SWPPP Guide*, Chapter 8.

Individual(s) Responsible for Training:

Ms. Dorothy Williams

Describe Training Conducted:

- General stormwater and BMP awareness training for staff and subcontractors:

Ms. Williams will conduct informal training for all staff, including subcontractors, on the site. The training will be conducted primarily via tailgate sessions and will focus on avoiding damage to stormwater BMPs and preventing illicit discharges. The tailgate sessions will be conducted biweekly and will address the following topics: Erosion Control BMPs, Sediment Control BMPs, Non-Stormwater BMPs, Waste Management and Materials Storage BMPs, and Emergency Procedures specific to the construction site. (See Appendix J – Training Log)

- Detailed training for staff and subcontractors with specific stormwater responsibilities:

Ms. Williams will provide formal training to all staff and subcontractors with specific stormwater responsibilities, such as installing and maintaining BMPs. The formal training will cover all design and construction specifications for installing the BMPs and proper procedures for maintaining each BMP. Formal training will occur before any BMPs are installed on the site. (See Appendix J – Training Log)

SECTION 7: FINAL STABILIZATION

Instructions:

- Describe procedures for final stabilization. If you complete major construction activities on part of your site, you can document your final stabilization efforts for that portion of the site. Many permits will allow you to then discontinue inspection activities in these areas (be sure to check your permit for exact requirements). You can amend or add to this section as areas of your project are finally stabilized.
- Update your site plans to indicate areas that have achieved final stabilization.
- For more on this topic, see *SWPPP Guide*, Chapter 9 and EPA's CGP Part 3, Subparts 3.11 and 3.13.D, and Part 5, Subpart 5.1.

Permanent Seeding

BMP Description: Permanent seeding will be applied immediately after the final design grades are achieved on portions of the site but no later than 14 days after construction activities have permanently ceased. After the entire site is stabilized, any sediment that has accumulated will be removed and hauled off-site for disposal at Springfield Landfill. Construction debris, trash and temporary BMPs (including silt fences, material storage areas, sanitary toilets, and inlet protection) will also be removed and any areas disturbed during removal will be seeded immediately.

Seedbed Preparation

- a. In areas where disturbance results in subsoil being the final grade surface, topsoil will be spread over the finished area at minimum depth of 2 to 6 inches.
- b. The seedbed will be free of large clods, rocks, woody debris and other objectionable materials.
- c. Fertilizer and lime will be applied to the seedbed according to the manufacturer's recommendations or soil tests (soil tests are omitted from this example SWPPP).
- d. The top layer of soil will be loosened to a depth of 3–5 inches by raking, tilling, disking or other suitable means.

Grass Selection/Application

- a. Common areas at the site will be stabilized with a mixture of Tall Fescue, Creeping Red Fescue and Redtop at an application rate of 30 pounds per acre or 0.95 pounds per 1,000 square feet. Lawns will be stabilized with a mixture of Kentucky Blue Grass and Creeping Red Fescue at an application rate of 100 pounds per acre or 2.3 pounds per 1,000 square feet.
- b. Seed will be applied uniformly by hydroseeding or broadcasting. Where broadcasting is used, the seed will be covered with .25 inches of soil or less, by cultipacking or raking.

Mulching

- a. Hydromulch will be applied immediately following seeding at an application rate of 90–100 pounds (2–3 bales) per 1,000 square feet.

<i>Installation Schedule:</i>	Portions of the site where construction activities have permanently ceased will be stabilized, as soon as possible but no later than 14 days after construction ceases.
<i>Maintenance and Inspection:</i>	All seeded areas will be inspected weekly during construction activities for failure and after storm events until a dense cover of vegetation has been established. If failure is noticed at the seeded area, the area will be reseeded, fertilized, and mulched immediately. After construction is completed at the site, permanently stabilized areas will be monitored until final stabilization is reached.
<i>Responsible Staff:</i>	RBI Development / <i>COASTAL CREEK BUILDING 6</i>

SECTION 8: CERTIFICATION AND NOTIFICATION

Instructions:

- The SWPPP should be signed and certified by the construction operator(s). Attach a copy of the NOI and permit authorization letter received from EPA or the state in Appendix D.
- For more information, see EPA's CGP Part 3, Subpart 3.12.A-D and Appendix G, Section 11.

I certify under penalty of law that this document and all attachments were prepared under my direction or supervision in accordance with a system designed to assure that qualified personnel properly gathered and evaluated the information submitted. Based on my inquiry of the person or persons who manage the system, or those persons directly responsible for gathering the information, the information submitted is, to the best of my knowledge and belief, true, accurate, and complete. I am aware that there are significant penalties for submitting false information, including the possibility of fine and imprisonment for knowing violations.

Name: Doug Lewis Title: Owner
Signature: Doug Lewis Date: 12/3/05

SECTION 8: CERTIFICATION AND NOTIFICATION

Instructions:

- The SWPPP should be signed and certified by the construction operator(s). Attach a copy of the NOI and permit authorization letter received from EPA or the state in Appendix D.
- For more information, see EPA's CGP Part 3, Subpart 3.12.A-D and Appendix G, Section 11.

I certify under penalty of law that this document and all attachments were prepared under my direction or supervision in accordance with a system designed to assure that qualified personnel properly gathered and evaluated the information submitted. Based on my inquiry of the person or persons who manage the system, or those persons directly responsible for gathering the information, the information submitted is, to the best of my knowledge and belief, true, accurate, and complete. I am aware that there are significant penalties for submitting false information, including the possibility of fine and imprisonment for knowing violations.

Name: DARREN SHAW Title: OWNER - COASTAL CREEK BUILDING

Signature: Darren Shaw Date: 6/1/2004

SWPPP APPENDICES

Attach the following documentation to the SWPPP:

Appendix A – General Location Map

Appendix B – Site Maps

Appendix C – Construction General Permit

Appendix D – NOI and Acknowledgement Letter from EPA/State

Appendix E – Inspection Reports

Appendix F – Corrective Action Log

Appendix G – SWPPP Amendment Log

Appendix H – Subcontractor Certifications/Agreements

Appendix I – Grading and Stabilization Activities Log

Appendix J – Training Log

Appendix K – Delegation of Authority

Appendix L – Additional Information